

Counterbalance valves CB-03 (for CR/GR-M motor)

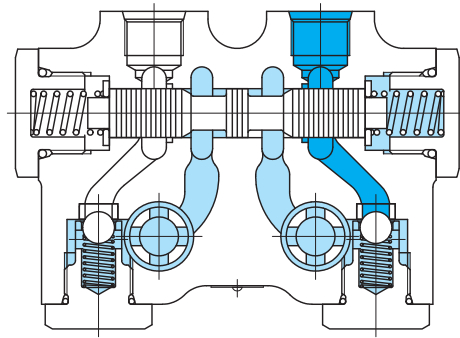

Functional Symbols

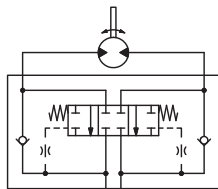

CB-03-*10

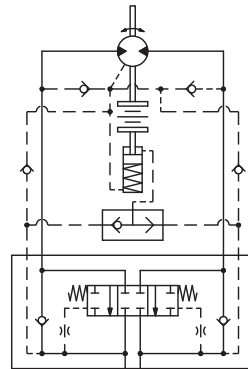

CB-03-*G10

Model Code

(F3)-CB-03-(B)(G)-10-(S1)

1 2 3 4 5 6 7

- 1 Hydraulic fluid
Omit: mineral oil
F3: Phosphate ester
- 2 Counterbalance Valve
- 3 Size
- 4 Porting
Omit: 3/4-16UNF threaded port (SAE O-ring seal)
B: (3/4-16UNF) x with G3/8 hose nipple
E: (3/4-16UNF) x with Rc3/8 bushing
H: (3/4-16UNF) x with G3/8 elbow hose nipple
- 5 Applicable motor
Omit: CR Series, GR-M(E) Series
G: For GR-MC Series
- 6 Design no.
- 7 Special feature
S1: No mounting bolt, mounting nut or O-ring (used with when stacking counterbalance valve module BR-03)

Specifications

Size	Max. Working Pressure MPa	Rated Flow L/min	Min. Switching Pressure MPa	Guaranteed Pressure Proof MPa	Weight kg
03	21	40	0.5	28	3.5

Characteristics Curve (at 46 mm²/s) (typical examples)

Pressure Drop Characteristics

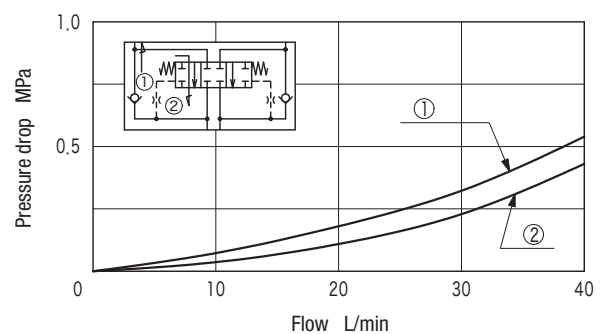

- (1): Check valve free flow direction
- (2): Control flow direction

Dimensions

CB-03-*

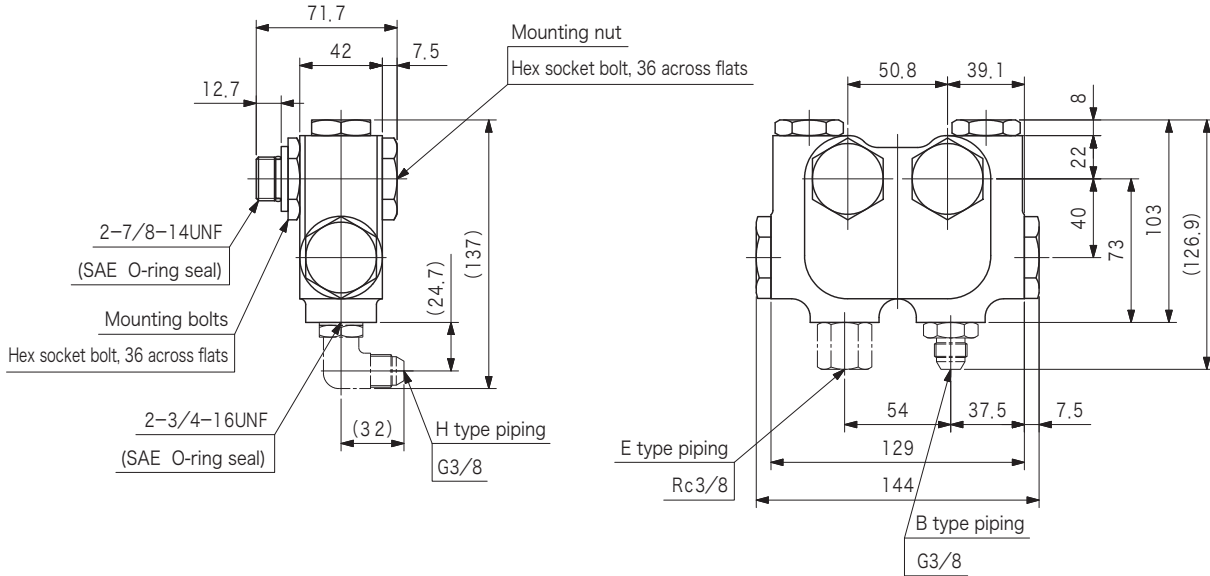

CB-03-*G

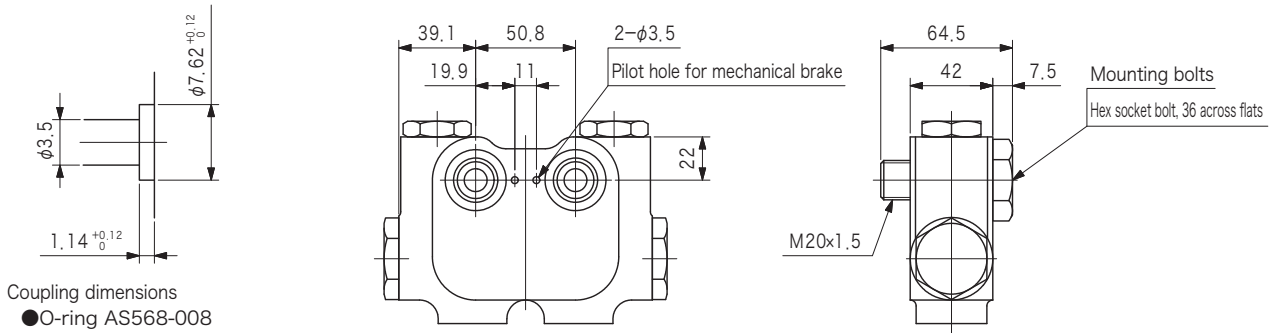

Note: CB-03-*G is a counterbalance valve which is used exclusively for the GR-MC*-*-C* motors as shown in the figure below.

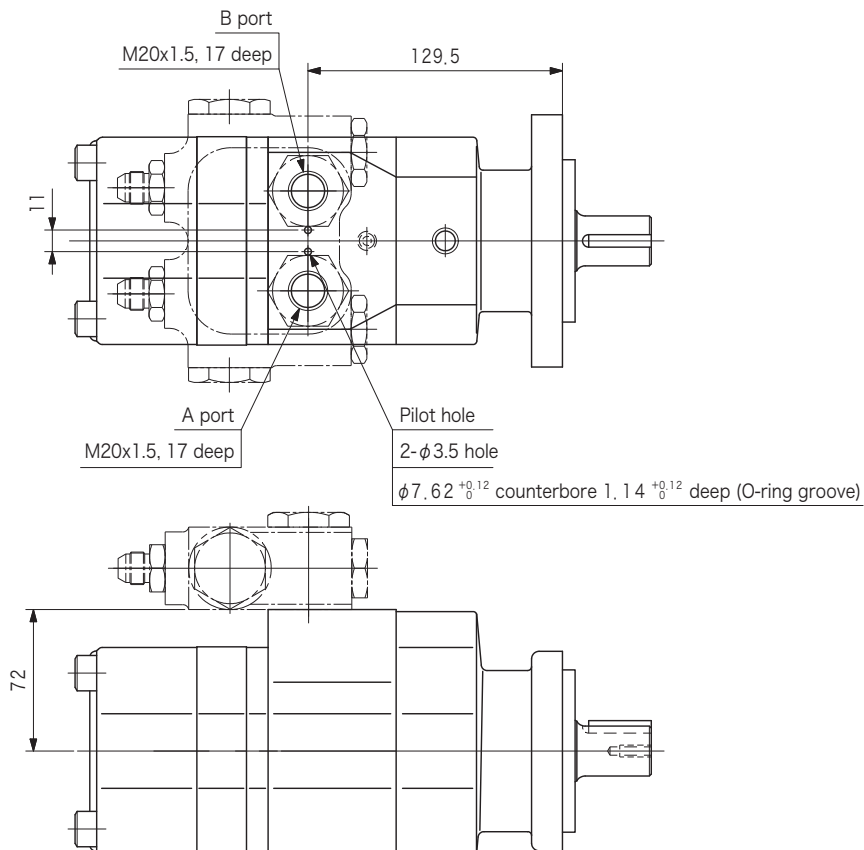

Construction

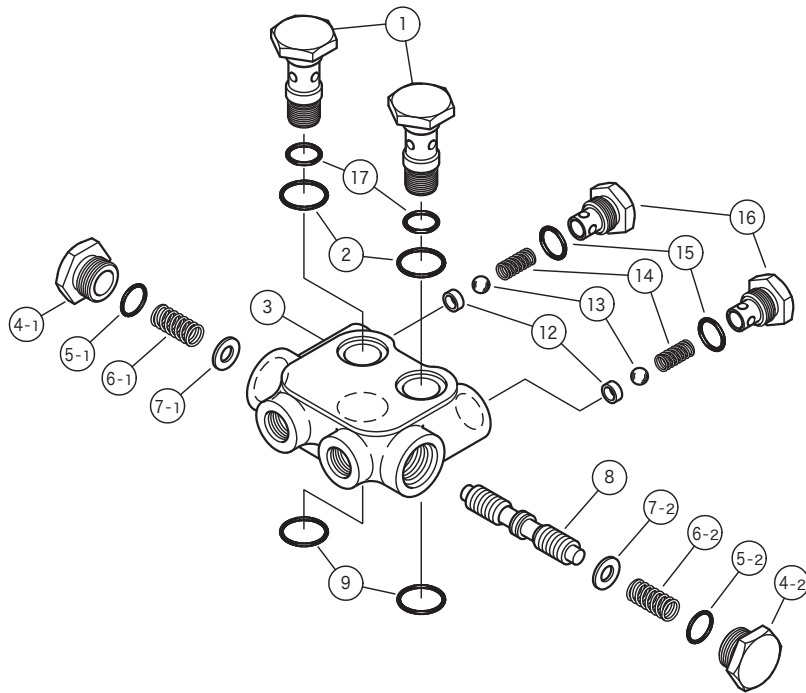

Note: For CB-03-*G-10, ⑰ O-ring is not used.

O-ring

No.	Part No.	Standard	Qty
2	008002419	JIS B 2401 1B-P25	2
5	008002319	JIS B 2401 1B-P24	2
9	008002419	JIS B 2401 1B-P25	2
15	007991019	AS568-910 (NBR, Hs90)	2
17	007991019	AS568-910 (NBR, Hs90)	2

CB-03 Counterbalance Valve and BR-03 Brake Valve Combination Unit

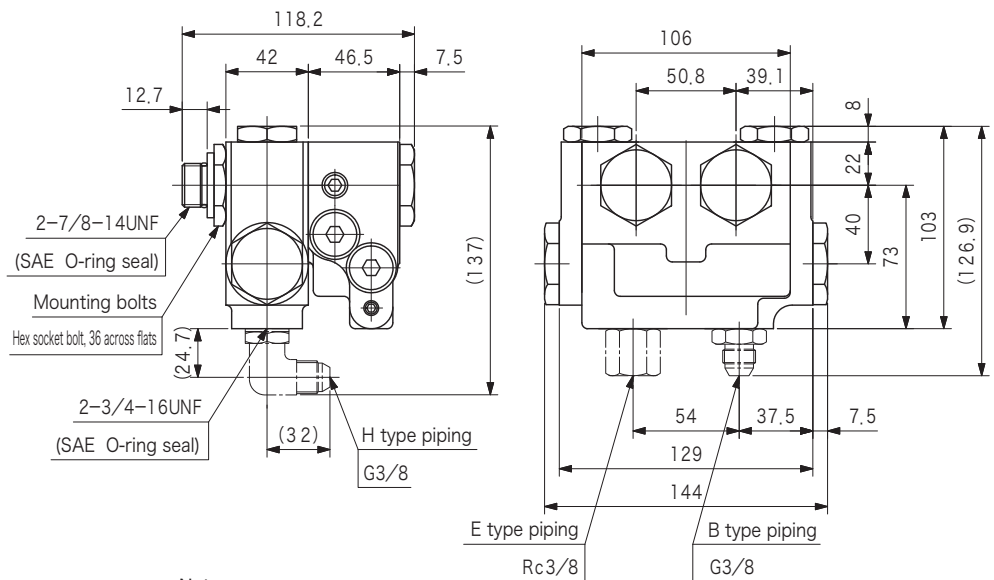
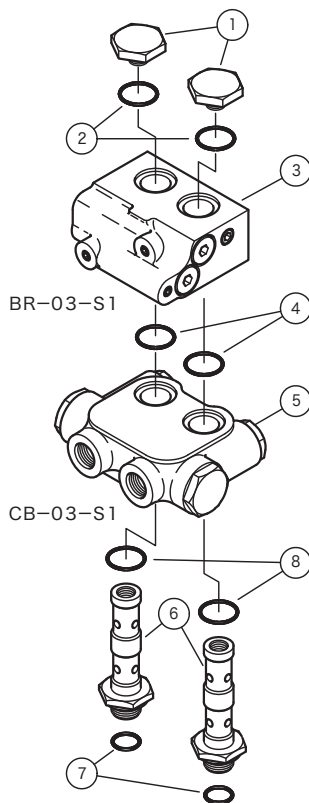

Note:

- When CB-03 and BR-03 are to be used in combination, select 'S1' type for each valve.
- CB-03-S1 and BR-03-S1 are for ③, ⑤ only and do not include O-rings, mounting nuts, and mounting bolts which must be ordered separately.

O-ring

No.	Part No.	Standard	Qty
2	008002419	JIS B 2401 1B-P25	2
4	008002419	JIS B 2401 1B-P25	2
7	007991019	AS568-910 (NBR, Hs90)	2
8	008002419	JIS B 2401 1B-P25	2