

High torque low speed vane motors (multi-torque type) MHT

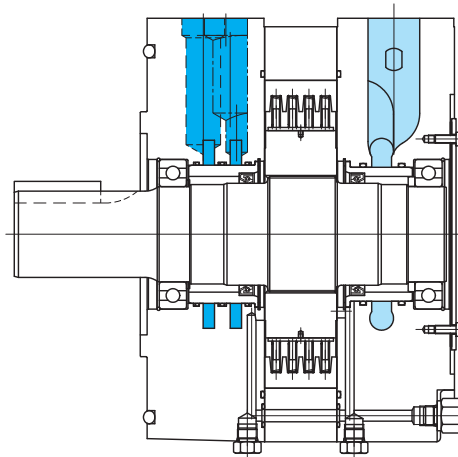

Functional Symbols

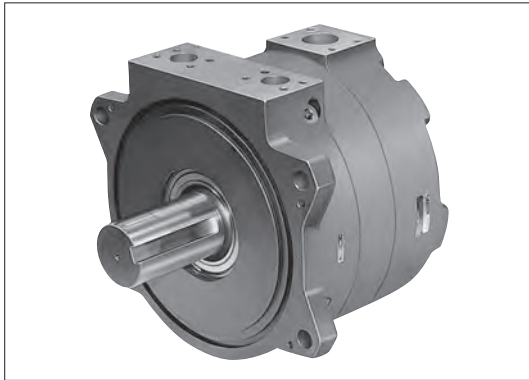
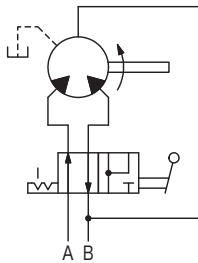

With special switching valve

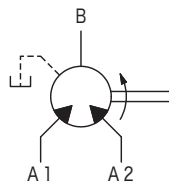

- Special switching valves enables easy switching from low speed high torque to high speed low torque.
- Balanced type vane motor provides wide range of speeds and torques.
- Compact with large torque output.
- Smooth, stable low speeds even at 10 rpm.
- Compact design which eliminates need for gear boxes and reduction gears.

Model Code

MHT500/250/250-R1-35-JA-S12(9)



- 1 Low speed high torque vane motor
- 2 Full torque displacements
24, 32, 50, 70, 90, 150, 190, 250, 380, 500, 750, 1000
- 3 Partial torque displacements
Refer to "Specifications".
- 4 Shaft
R1: Parallel shaft with square key (standard)
- 5 Design no.
JA-12: MHT24, 32
15-JA: MHT70, 90
JA-30: MHT50
35-JA: MHT150, 190, 250, 380, 500, 750 (2-speed), 1000 (2-speed)
JA-35: MHT750 (4-speed), 1000 (3-speed)

- 6 Special feature
Omit: bi-directional rotation models (applied to MHT50/25/25)
S12: Unidirectional right (CW) rotation (standard)
S123: unidirectional right (CW) rotation with flange type body mounting (for MHT70 and above)
Note: Consult Tokyo Keiki for unidirectional left (CCW) rotation models.
- 7 Special switching valve
Omit: no switching valve
8: Switching valve (applicable for MHT70/45/25 only)
9: Switching valve (applicable to all models except above model.)
Note: Use switching valve for MHT750/625/500/375 and MHT1000/750/500.

● **Special Switching Valve** Refer to below for the special switching valve.

DMHT500-2-10-JA



- 1 Switching valve for MHT motors
- 2 Number

Number	32	50	90	150	250	500	750	1000
Applicable Motor (multi-torque)	MHT24 MHT32	MHT50	MHT70 MHT90	MHT150	MHT190 MHT250	MHT380 MHT500	MHT750	MHT1000

- 3 Motor speeds
2: 2 speed
3: 3 (or 4) speed

- 4 Design no.
Design no. is "-10-JA-S1" for MHT250, 500, 750 (2-speed) and MHT1000 (2-speed). Design no. is "JA-10-S3" for MHT750 (3-speed) and MHT1000 (3-speed).

Specifications

Model Code	Design No.	Displacement cm ³ /rev		Theoretical Torque (Pressure Differential 0.7 MPa) N·m				Max. Working Pressure MPa	Speed min ⁻¹		Weight kg			
		Full Torque	Partial Torque	Full Torque	Partial Torque	Minimum	Maximum		Motor	Special Switching Valve				
2-Speed Models														
MHT24/12/12	JA-12	298	149	33	16.5	14	10	400	55	13				
MHT32/16/16	JA-12	398	199	44	22			400	55	13				
MHT50/25/25	JA-30	620	310	69	34.5			350	95	24				
MHT70/35/35	15-JA	868	434	97	48.5			300	110	26.5				
MHT90/45/45	15-JA	1116	558	124	62			300	110	26.5				
MHT150/75/75	35-JA	1860	930	207	104			250	165	30				
MHT190/95/95	35-JA	2360	1180	263	131			200	240	38				
MHT250/125/125	35-JA	3100	1550	346	173			200	240	38				
MHT380/190/190	35-JA	4720	2360	526	263			200	335	39				
MHT500/250/250	35-JA	6200	3100	690	345			200	335	39				
MHT750/375/375	35-JA	9300	4650	1040	520			100	420	40				
MHT1000/500/500	35-JA	12400	6200	1380	690			75	505	41				
3-Speed Models														
MHT70/45/25	15-JA	868	558	310	97	62	34.5	14	10	300	110	26.5		
MHT1000/750/500	JA-35	12400	9300	6200	1380	1040	690			150	560	81		
4-Speed Models														
MHT750/625/500/375	JA-35	9300	7750	6200	4650	1040	860	690	520	14	10	150	470	79

•3, 4-speed types are available with other combinations than the above chart. Consult Tokyo Keiki for details.

Characteristics Curves (at 25 mm²/s) (typical examples)

Characteristics Curves (1): 7 MPa (2): 14 MPa

2-Speed Models

MHT 24/12/12
MHT 32/16/16

Full Torque

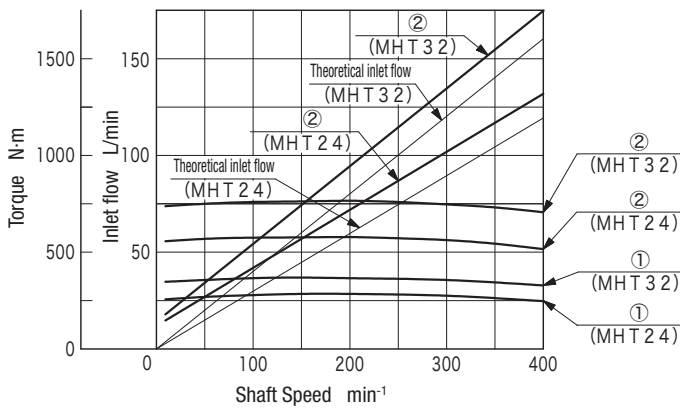

MHT 50/25/25

Full Torque

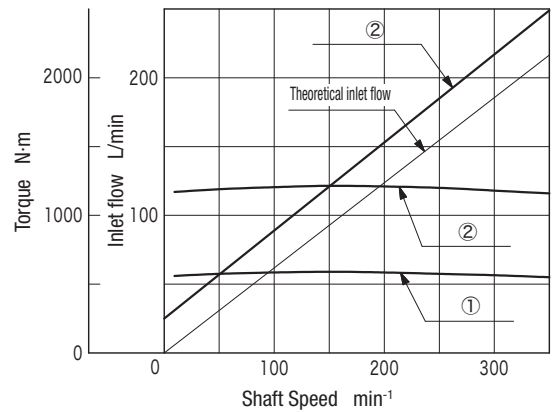

Partial Torque

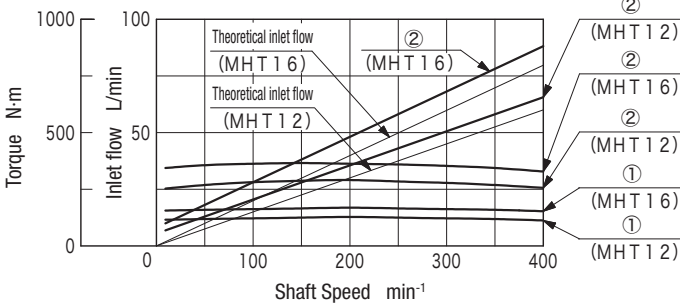

Partial Torque

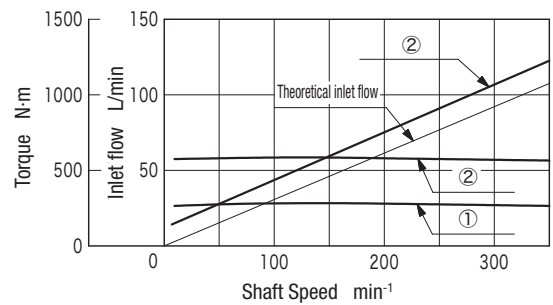

N
3-2

Motors (Vane)

Characteristics Curves (at 25 mm²/s) (typical examples)

Characteristics Curves (1): 7 MPa (2): 14 MPa

MHT 70/35/35
MHT 90/45/45

MHT 150/75/75

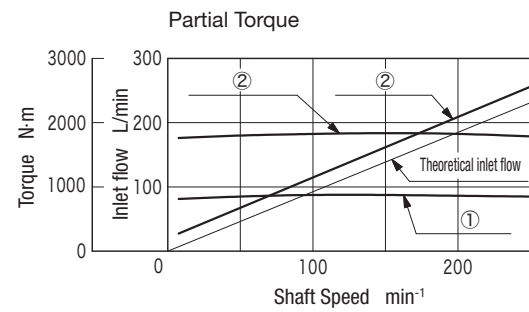
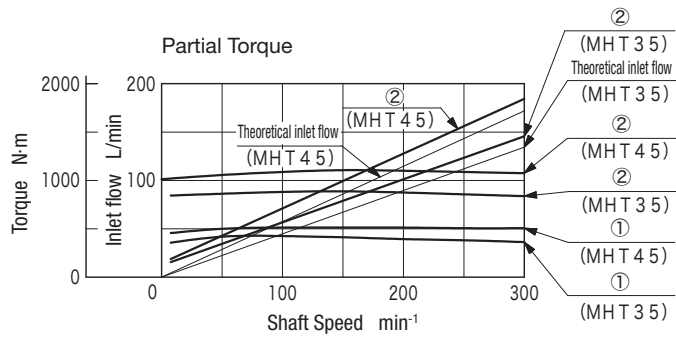
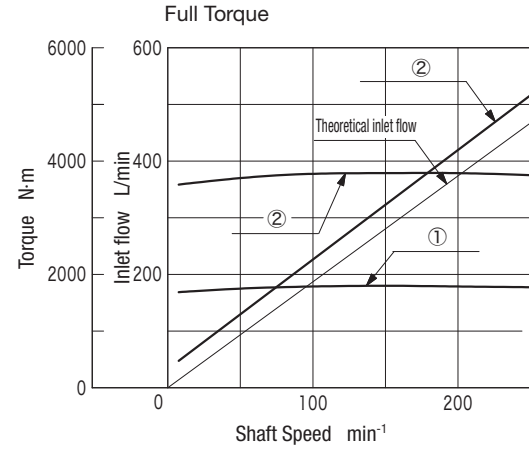
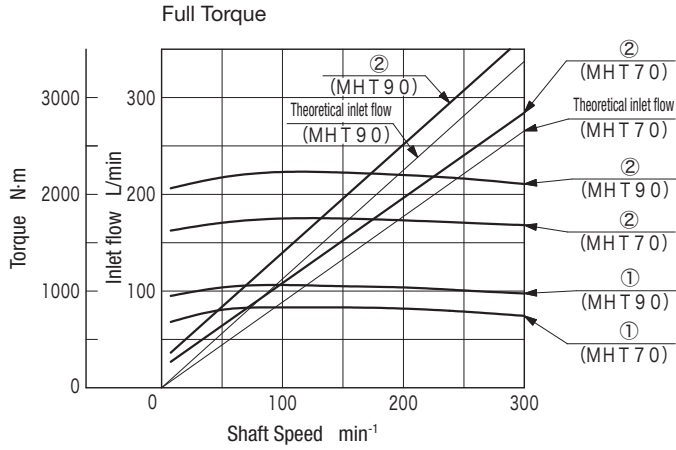

MHT 190/95/95
MHT 250/125/125

MHT 380/190/190
MHT 500/250/250

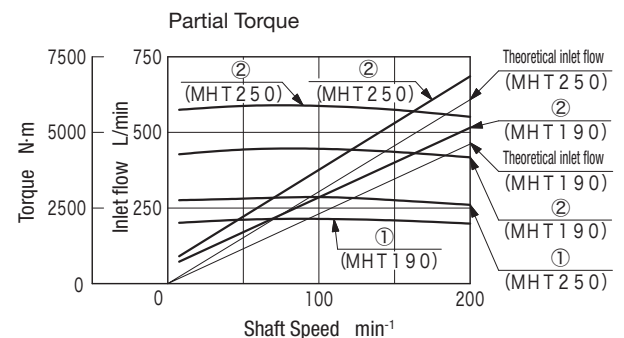
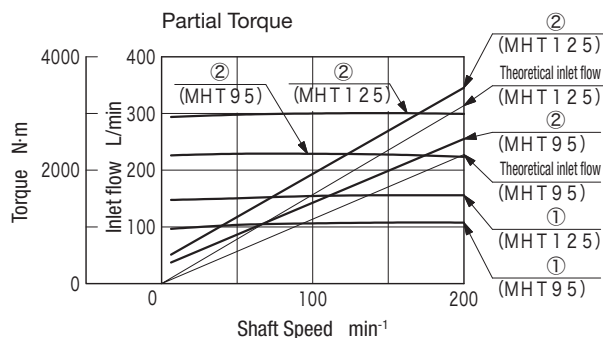
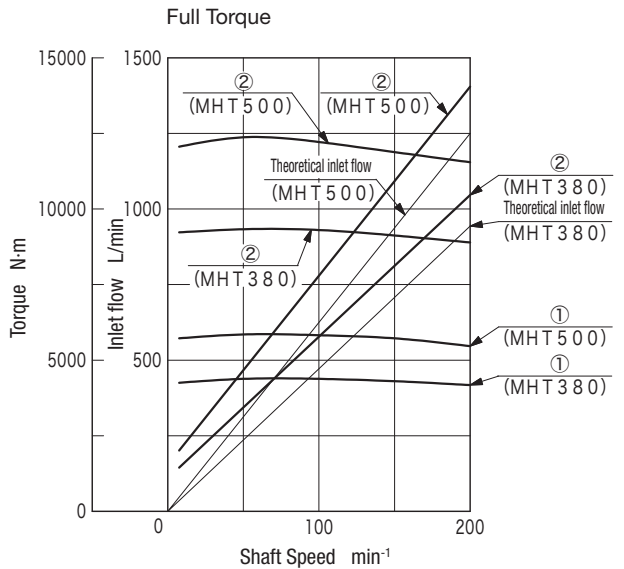
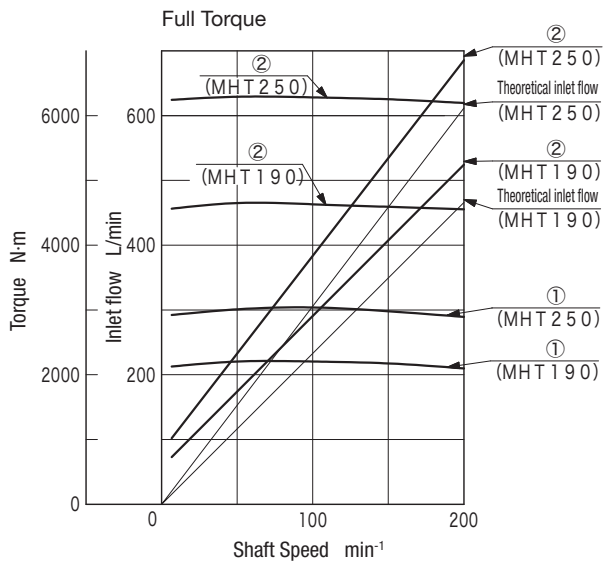

Characteristics Curves (at 25 mm²/s) (typical examples)

Characteristics Curves (1): 7 MPa (2): 14 MPa
MHT 750/375/375

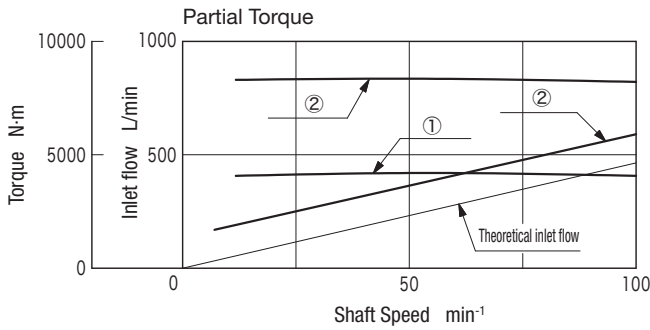
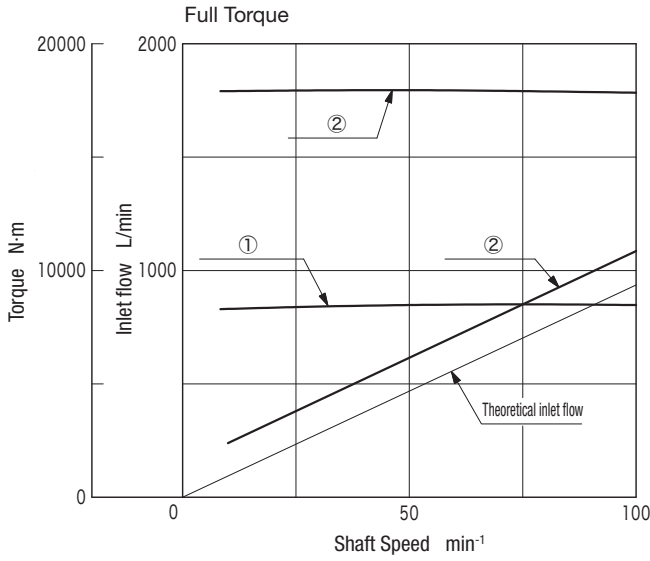

MHT 70/45/25

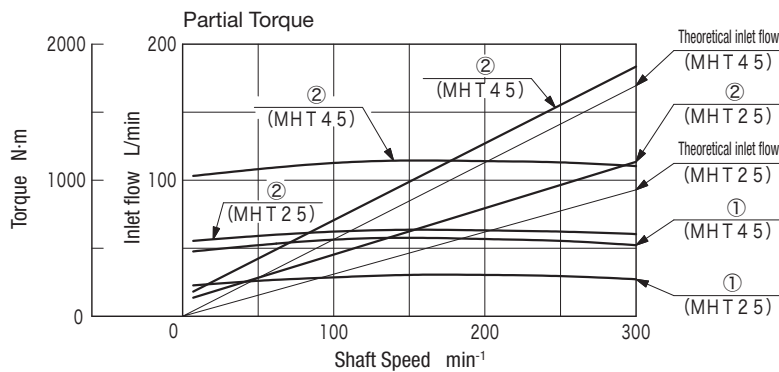
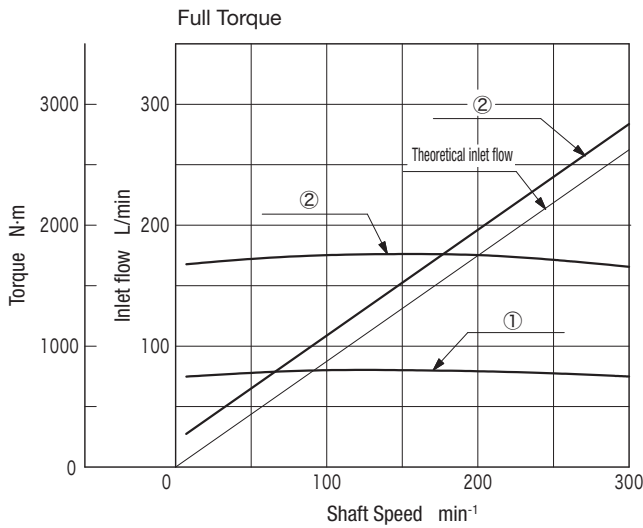

MHT 1000/500/500

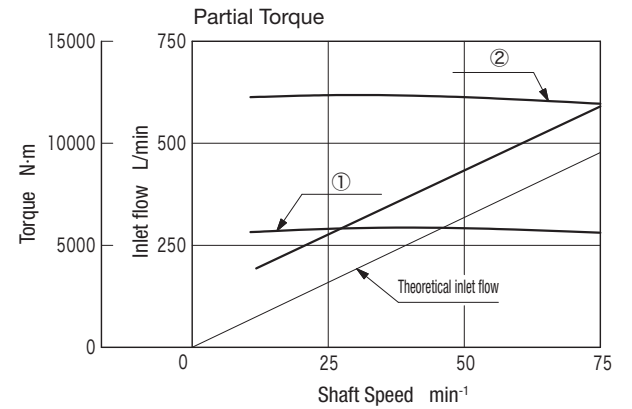
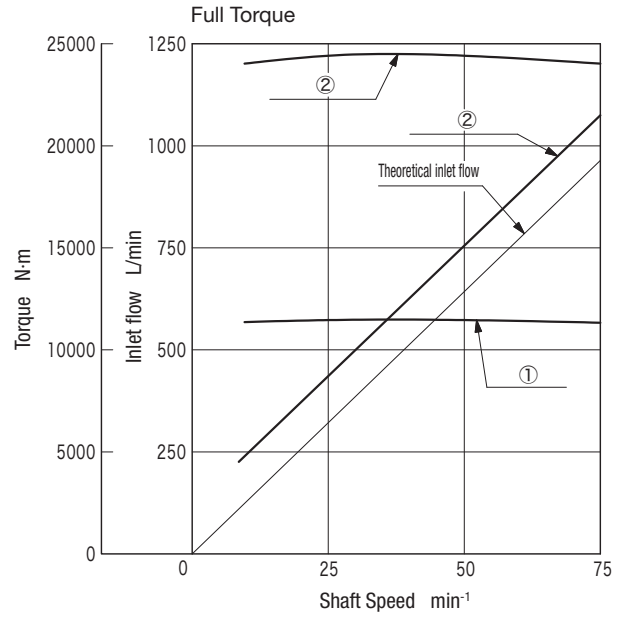

Characteristics Curves (at 25 mm²/s) (typical examples)

Characteristics Curves (1): 7 MPa (2): 14 MPa

3-Speed Models

MHT 1000/750/500

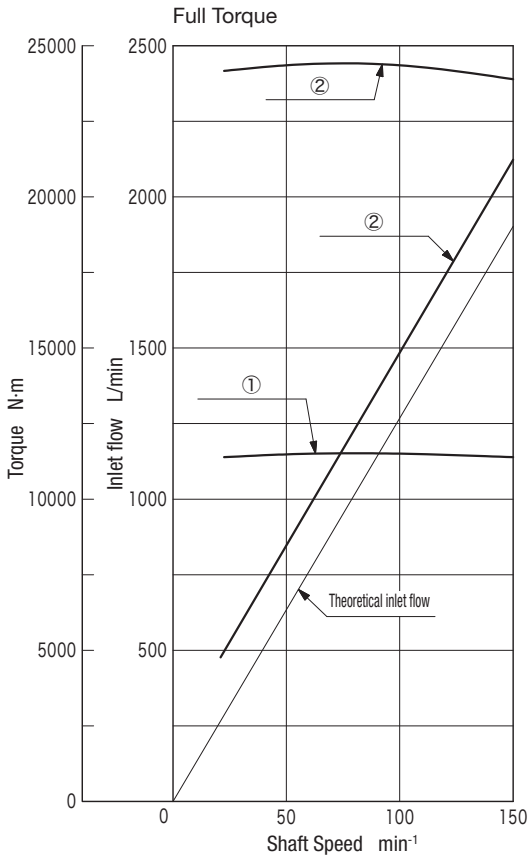

4-Speed Models

MHT 750/625/500/375

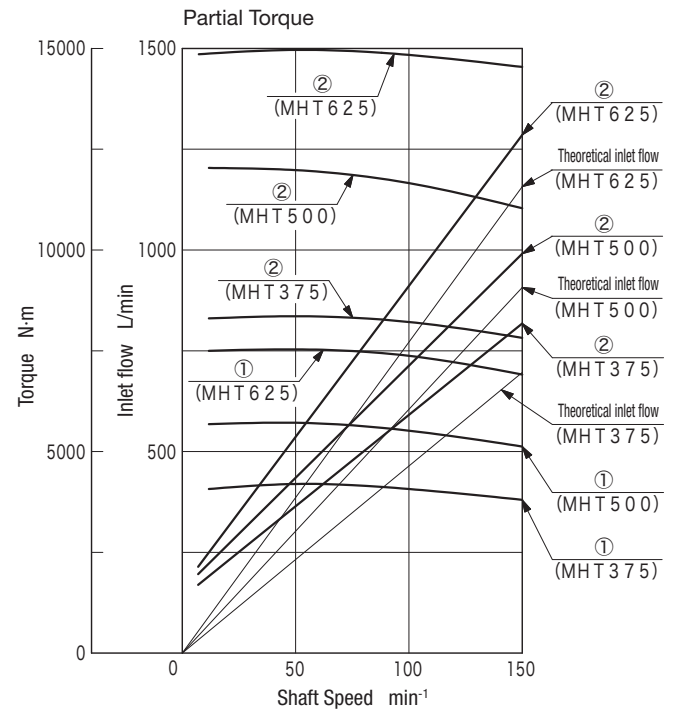
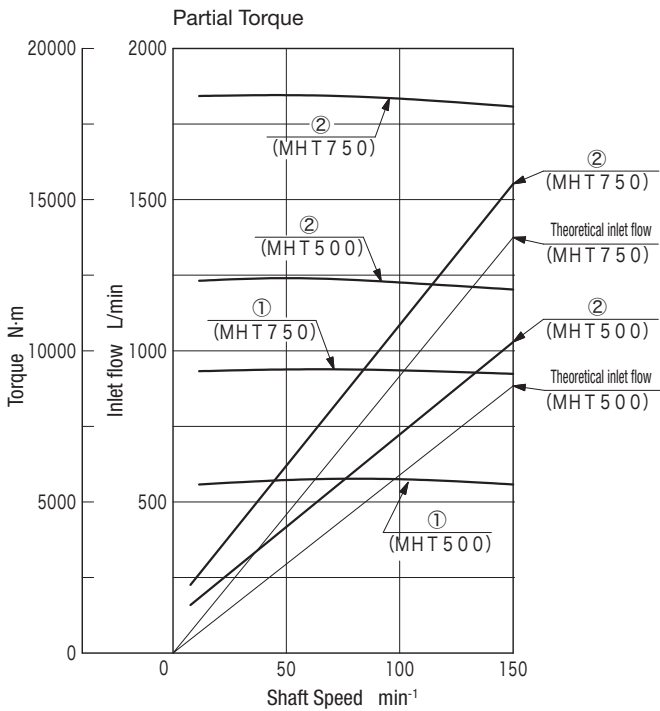
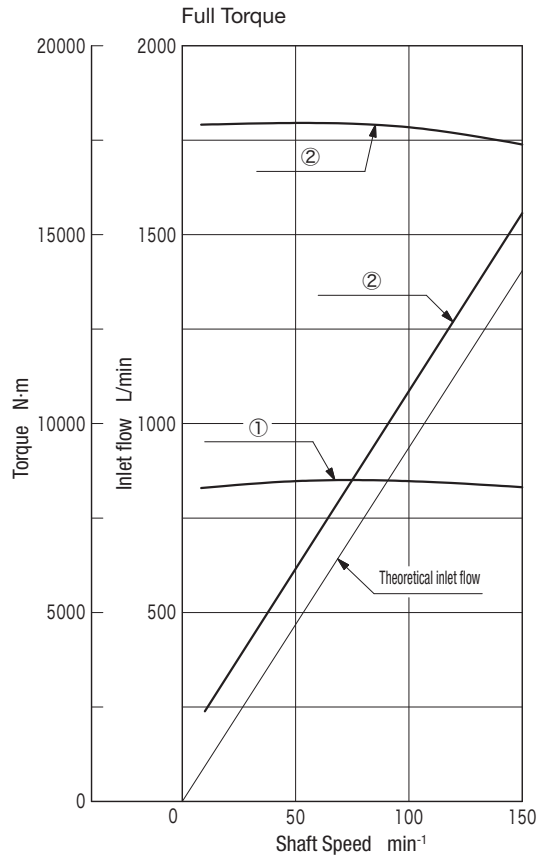

N
3-5
Motors (Vane)

Port Connection and Torque Switching

When using special switching valve

- Input port A, outlet port B (For left (CCW) rotation of MHT50/25/25, inlet and outlet ports are reverse).
- Switch lever only after motor is stopped. Lever should be switched fully until it contacts stopper pin. Tighten fixing bolt.

- Lever position and torque relationship is shown in the below table.

Motor Model		Torque Switching Condition				
		Max. Torque	High Torque	Medium Torque	Low Torque	Stop
2-speed	MHT24/12/12 MHT32/16/16					
	All 2 speeds models except for above model.					
3-speed	MHT70/45/25					
	MHT1000/750/750					
4-speed	MHT750/625/500/375					

When switching valve is not used

- Select desired torque and determine port connections from below table.

Torque Condition		A1 Port	A2 Port	B Port
Full Torque	Low speed, high-torque	Inlet	Inlet	Outlet
Partial Torque	High speed, low torque	Inlet	Outlet	
		Outlet	Inlet	

Multi-torque motor circuit

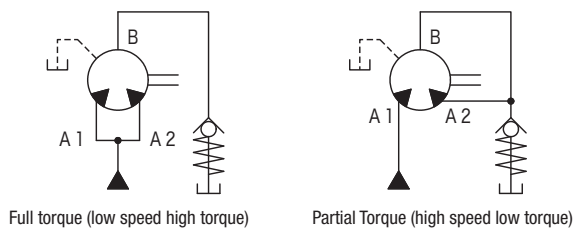

- For 3-speed models (MHT70/45/25), ports should be connected as the following table.

Torque Condition		A1 Port	A2 Port	B Port
Full Torque	Low speed, high-torque	Inlet	Inlet	Outlet
Partial Torque	Medium speed, medium torque	Outlet	Inlet	
		High speed, low torque	Inlet	Outlet

- Always use special switching valve for MHT750/625/500/375 and MHT1000/750/500.
- When using MHT50/25/25 with left hand rotation, the port connections shown in the above left table should be reversed.

Notes on Operation

- **Mounting**
Mount motor using 4 bolt holes on the mounting flange (for MHT24, 32, 50, use 6 mounting holes on body). See dimensions for information on bolt tightening torque.
- **Drain**
Drain should be piped directly to tank. Drain line allowable back pressure is 0.17 MPa.
- When motor is used at 3.5 MPa and under, or 50 rpm and over, confirm that drain flow is above values given in the table below. If drain flow is low, raise back pressure on motor outlet and increase drain flow.

Model Code	Drain cm ³ /min	Model Code	Drain cm ³ /min
MHT24/12/12	200	MHT190/95/95	200
MHT32/16/16		MHT250/125/125	
MHT50/25/25		MHT380/190/190	380
MHT70/35/35		MHT500/250/250	
MHT90/45/45		MHT750/375/375	570
MHT150/75/75		MHT1000/500/500	760

- **Rotation direction**
Uni-directional, either right (standard) or left rotation. Motor cannot be operated in both directions (except for MHT50/25/25).
Note: Consult Tokyo Keiki for left hand rotation motor.
- Motor cannot be used as brake (pump).
- **Back pressure**
Use a check valve, etc. to keep the motor outlet side pressure within the 0.5 to 3.5 MPa range.
- **Temperature difference between motor and oil must be kept below 28°C.** In any case motor is cool and oil temperature is high, run motor free from load at low speed (50min⁻¹ or under) until the temperature difference drops within the 28°C range.
- For initial startup, fill oil from each port and operate after motor is completely filled with oil.
- See Vane Motor Notes on Operation (page N0-1).

Piping Flanges (Conforming to SAE J 518c Standard Pressure)

When using special switching valve

Motor Model	Flange							
	A Port			B Port				
	Size	Threaded	Welded	Size	Threaded	Welded		
MHT24/12/12	1-1/4	FL1-10-10P-10-JA-S4-J	FL1-10-10W-10-JA	1-1/4	FL1-10-10P-10-JA-S21-J	FL1-10-10W-10-JA-S21		
MHT32/16/16					FL1-10-10P-10-JA-S19-J	FL1-10-10W-10-JA-S19		
MHT50/25/25								
MHT70/35/35	1-1/2	FL1-12-12P-10-JA-S4-J	FL1-12-12W-10-JA	1-1/2	FL1-12-12P-10-JA-S19-J	FL1-12-12W-10-JA-S19		
MHT70/45/25								
MHT90/45/45								
MHT150/75/75	2-1/2	FL1-20-20P-10-JA-S4-J	FL1-20-20W-10-JA	2-1/2	FL1-20-20P-10-JA-S19-J	FL1-20-20W-10-JA-S19		
MHT190/95/95								
MHT250/125/125								
MHT380/190/190								
MHT500/250/250								
MHT750/375/375								
MHT1000/500/500								
MHT750/625/500/375					FL1-20-20P-10-JA-S19-J	FL1-20-20W-10-JA-S19	FL1-20-20P-10-JA-S20-J	FL1-20-20W-10-JA-S20
MHT1000/750/500								

When switching valve is not used

Motor Model	Flange					
	A Port			B Port		
	Size	Threaded	Welded	Size	Threaded	Welded
MHT24/12/12	1	FL1-8-08P-10-JA-S4-J	FL1-8-08W-10-JA	1-1/4	FL1-10-10P-10-JA-S4-J	FL1-10-10W-10-JA
MHT32/16/16						
MHT50/25/25						
MHT70/35/35	1-1/4	FL1-10-10P-10-JA-S4-J	FL1-10-10W-10-JA	1-1/2	FL1-12-12P-10-JA-S4-J	FL1-12-12W-10-JA
MHT70/45/25						
MHT90/45/45						
MHT150/75/75	1-1/2	FL1-12-12P-10-JA-S4-J	FL1-12-12W-10-JA	2-1/2	FL1-16-16P-10-JA-S4-J	FL1-16-16W-10-JA
MHT190/95/95						
MHT250/125/125						
MHT380/190/190						
MHT500/250/250						
MHT750/375/375						
MHT1000/500/500						

- Flanges must be ordered separately.
- Hex socket bolt, spring washers, O-rings included.
- See page R7-1 for dimensions.

Dimensions

MHT24/12/12-R1-JA-12-S12
 MHT32/16/16-R1-JA-12-S12

Note:

- Special switching valve model, DMHT32-2-JA-10 (see page N3-13).

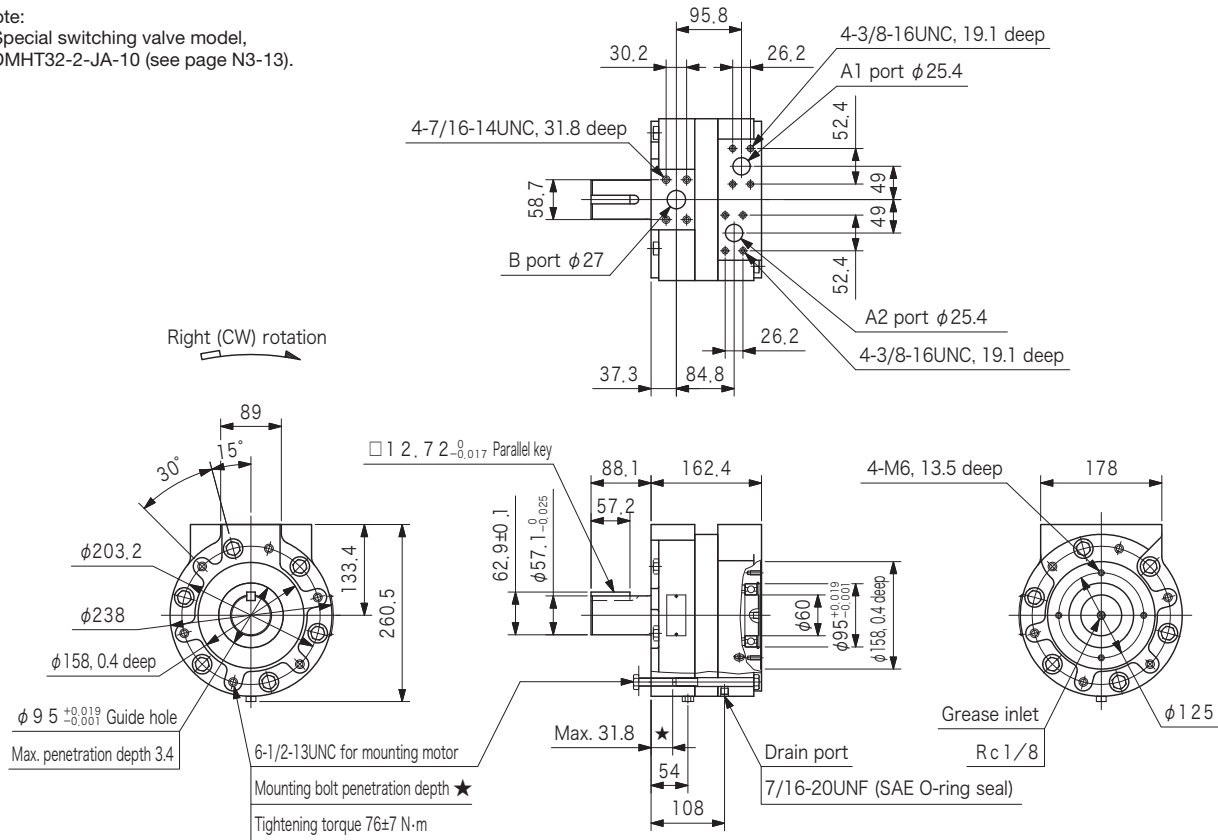

MHT50/25/25-R1-JA-30

Note:

- * can also be used as mounting guide holes.
- Special switching valve model, DMHT50-2-JA-10 (see page N3-13).

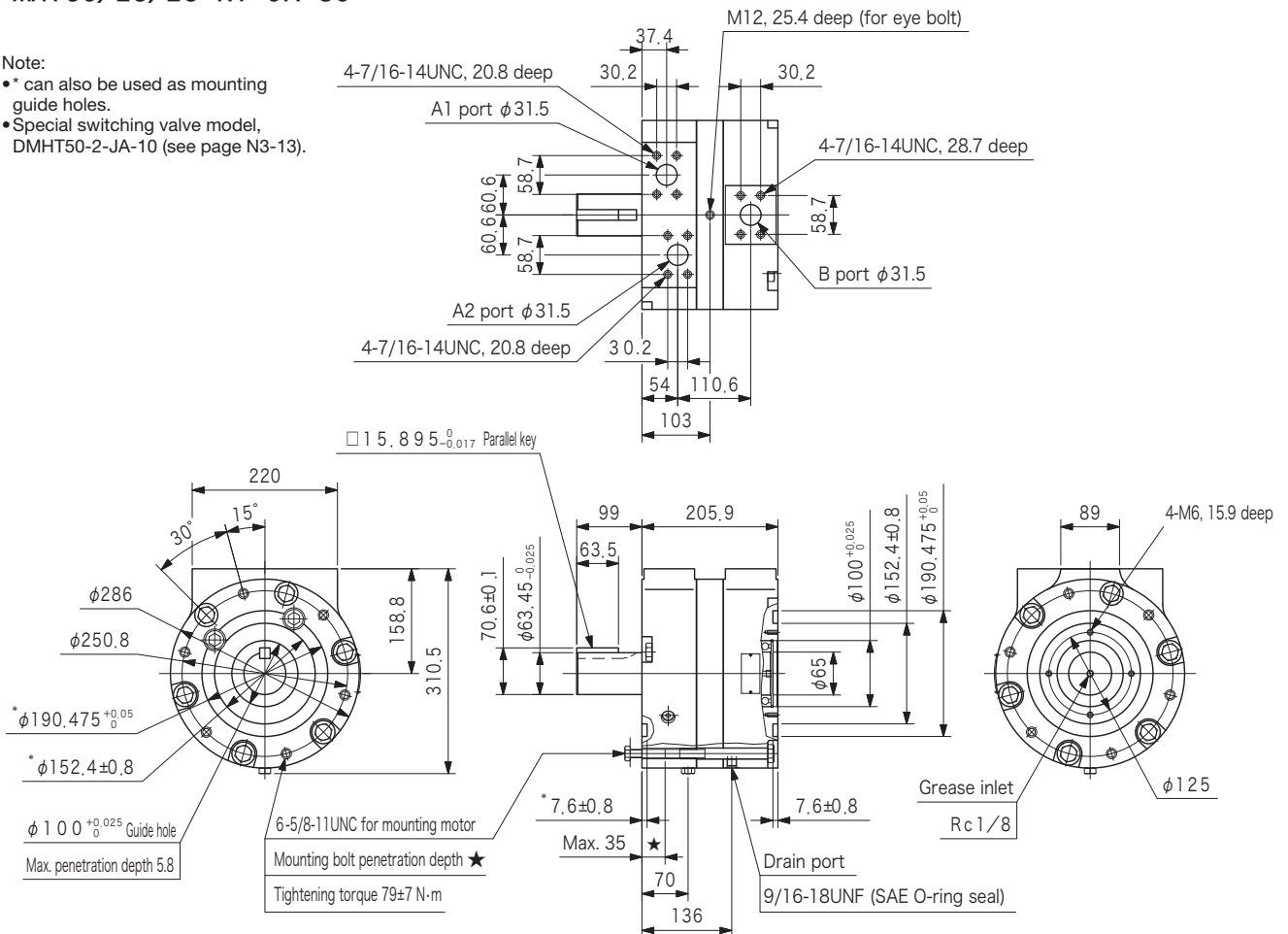

Dimensions

MHT70/35/35-R1-15-JA-S123
 MHT90/45/45-R1-15-JA-S123
 MHT70/45/25-R1-15-JA-S123

- Note:
- Shaft side end-face O-ring (AS568-450), 1 pc, is included.
 - Special switching valve for 2-speed model is DMHT90-2-JA-10.
 - Special switching valve for 3-speed model is DMHT90-3-JA-10. (see page N3-13).

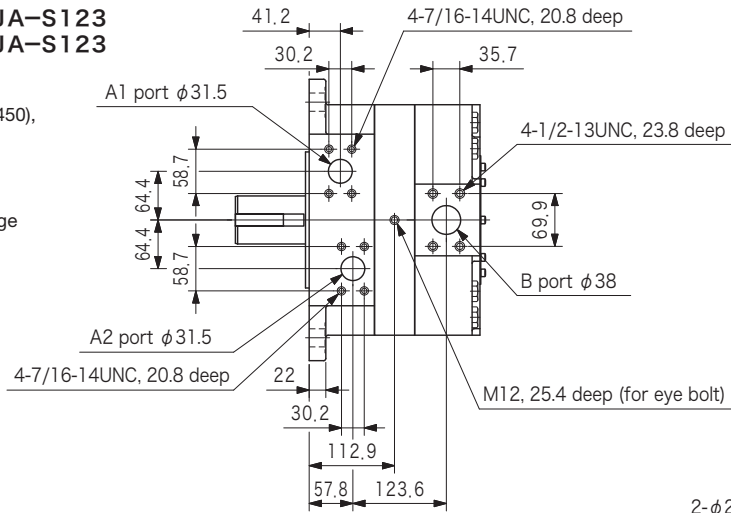

MHT150/75/75-R1-35-JA-S123

- Note:
- Shaft side end-face O-ring (AS568-450), 1 pc, is included.
 - Special switching valve model, DMHT150-2-JA-10 (see page N3-13).

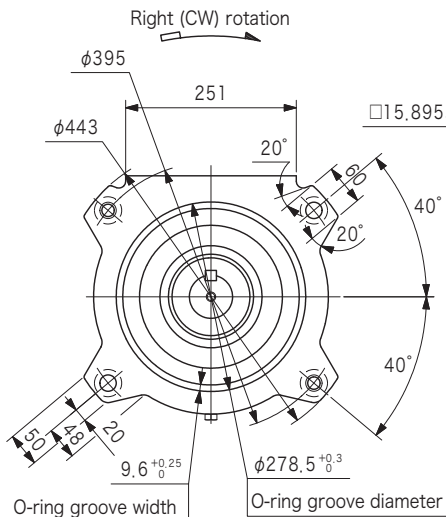
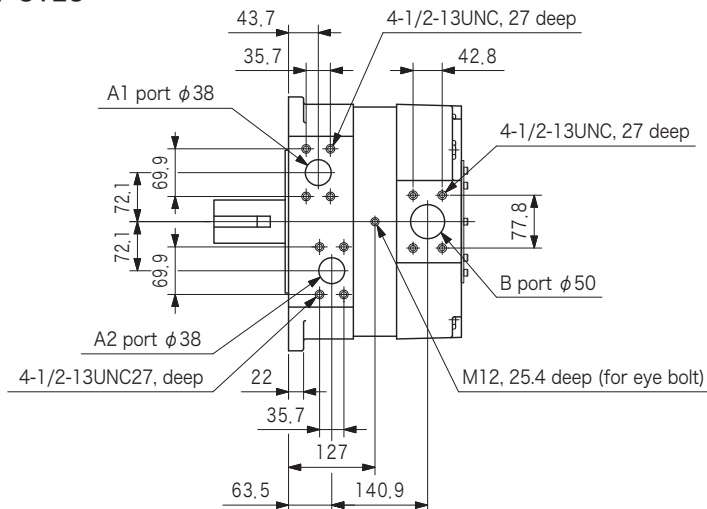

Dimensions

MHT190/95/95-R1-35-JA-S123 MHT250/125/125-R1-35-JA-S123

Note:

- Shaft side end-face O-ring (AS568-456), 1 pc, is included.
- Special switching valve model, DMHT250-2-10-JA-S1 (see page N3-14).

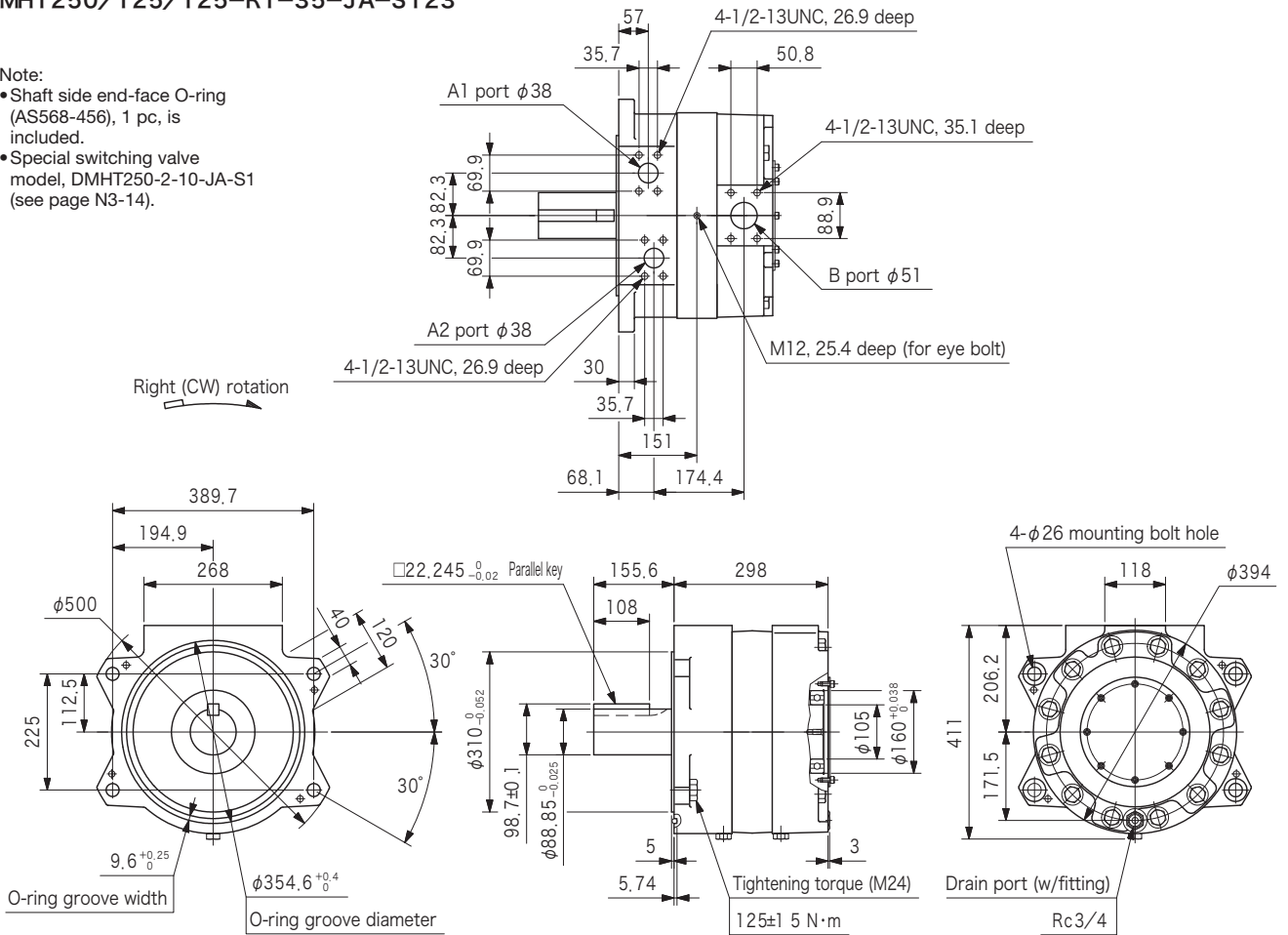

MHT380/190/190-R1-35-JA-S123 MHT500/250/250-R1-35-JA-S123

Note:

- Shaft side end-face O-ring (AS568-456), 1 pc, is included.
- Special switching valve model, DMHT500-2-10-JA-S1 (see page N3-14).

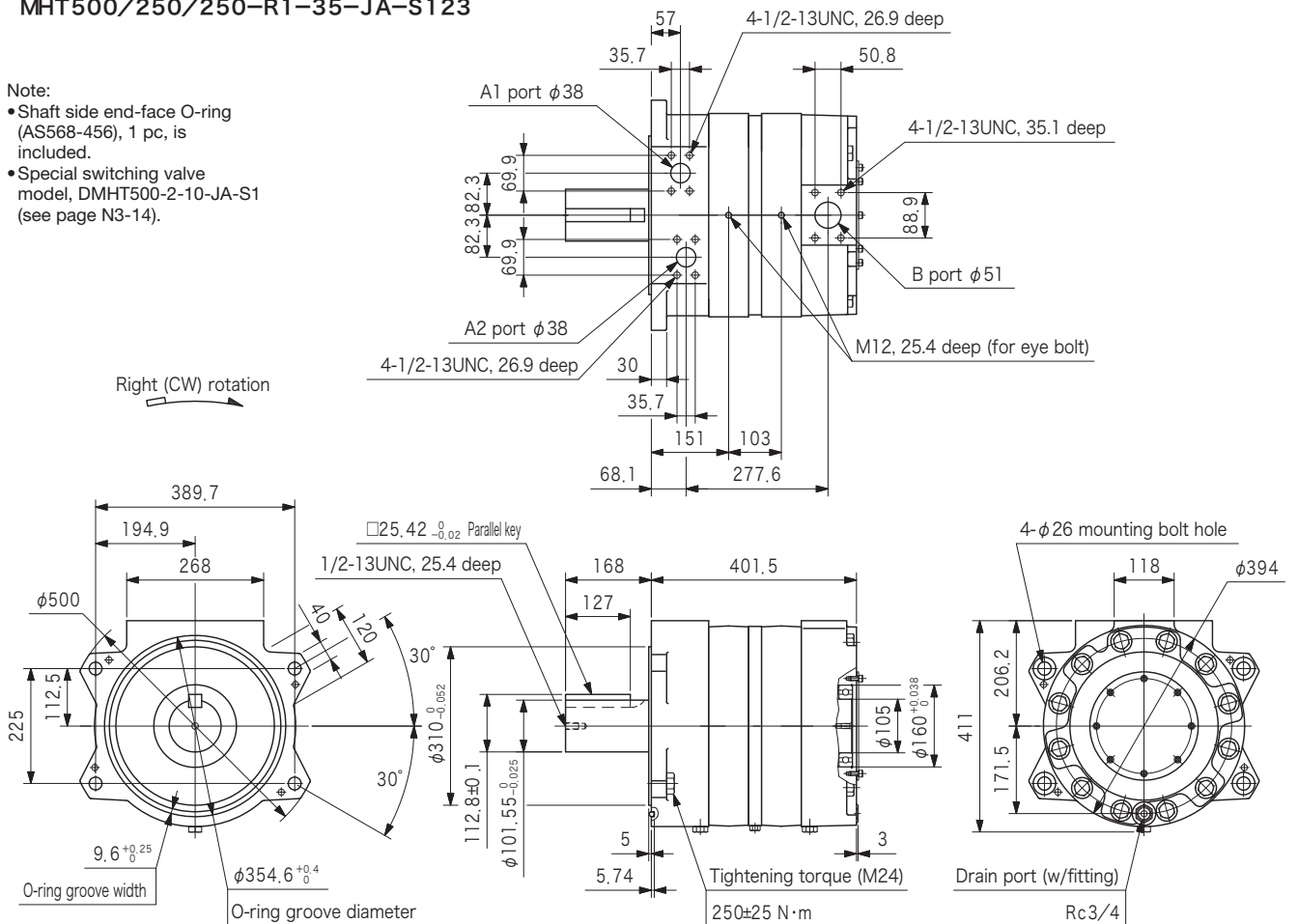

Dimensions

MHT750/375/375-R1-35-JA-S123

Note:

- Shaft side end-face O-ring (AS568-456), 1 pc, is included.
- Special switching valve model, DMHT750-2-10-JA-S1 (see page N3-14).

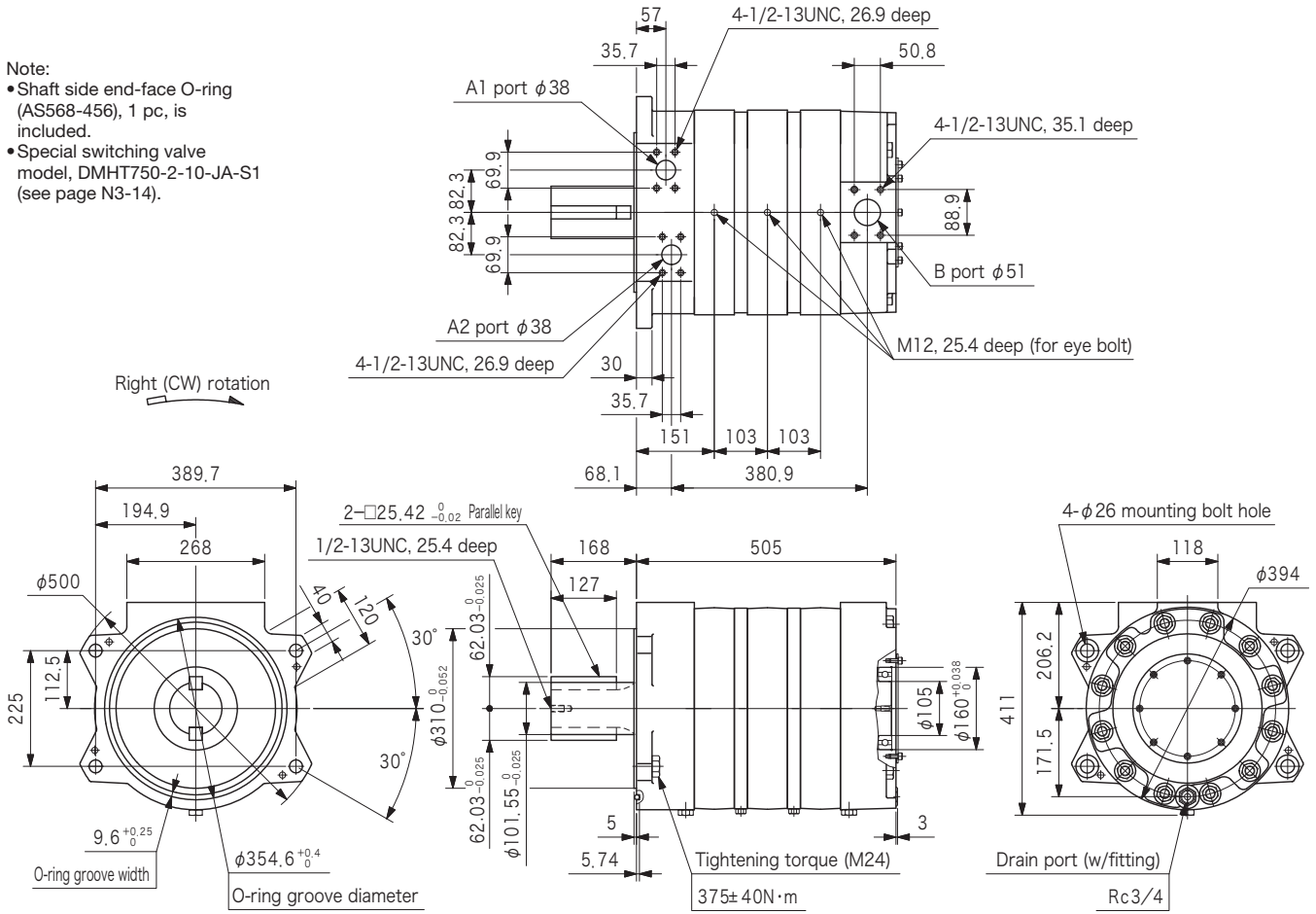

MHT750/625/500/375-R1-JA-35-S123

Note:

- Shaft side end-face O-ring (AS568-456), 1 pc, is included.
- Special switching valve model, DMHT750-3-JA-10-S3 (see page N3-14).
- Except where noted, dimensions are same as above MHT750/375/375.
- Flange surface dimensions for A1, A2, C1, and C2 ports are same.

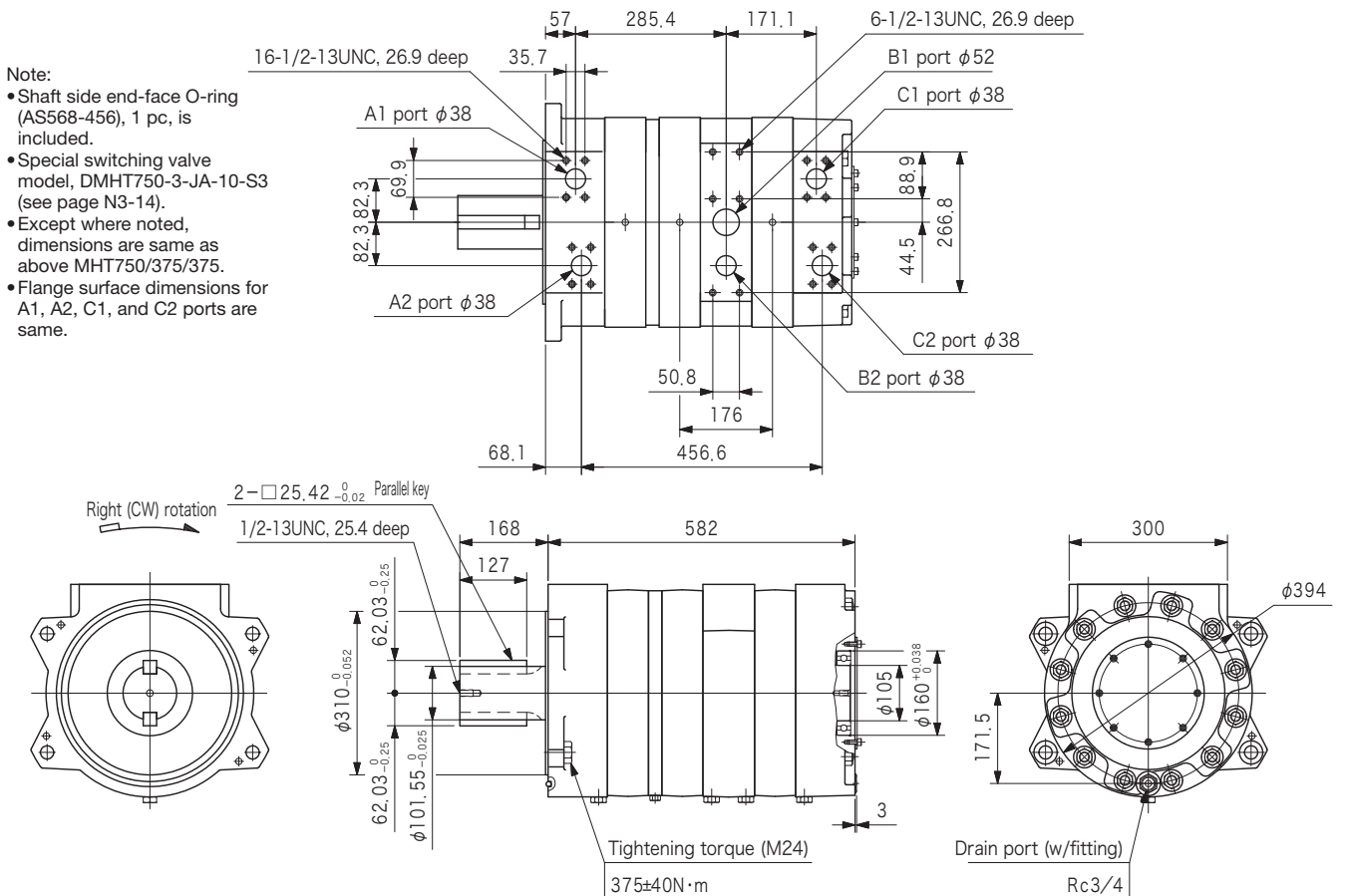

Dimensions

MHT1000/500/500-R1-35-JA-S123

Note:

- Shaft side end-face O-ring (AS568-456), 1 pc, is included.
- Special switching valve model, DMHT1000-2-10-JA-S1 (see page N3-14).

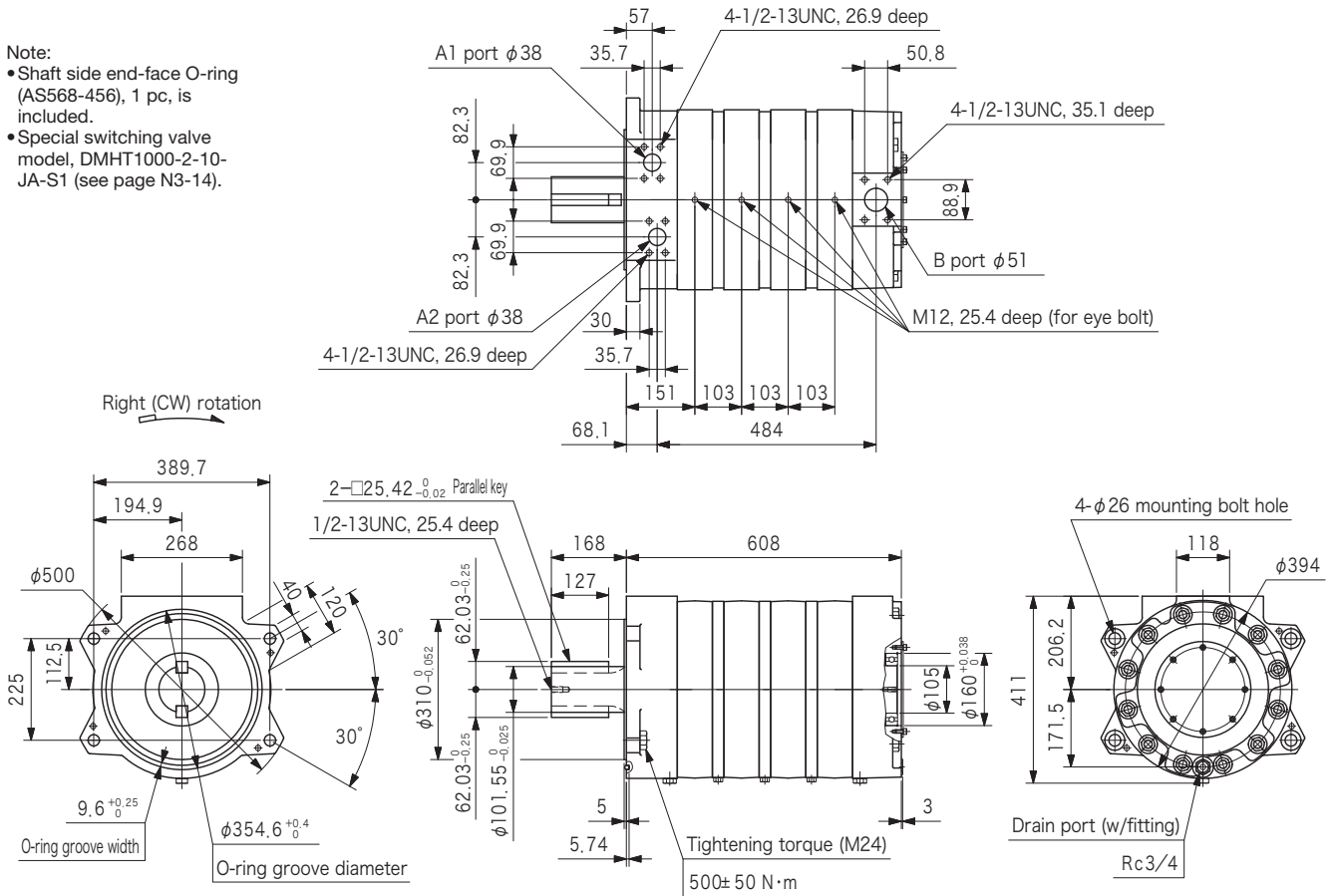

MHT1000/750/500-R1-JA-35-S123

Note:

- Shaft side end-face O-ring (AS568-456), 1 pc, is included.
- Special switching valve model, DMHT1000-3-JA-10-S3 (see page N3-14).
- Except where noted, dimensions are same as above MHT1000/500/500.
- Flange surface dimensions for A1, A2, C1, and C2 ports are same.

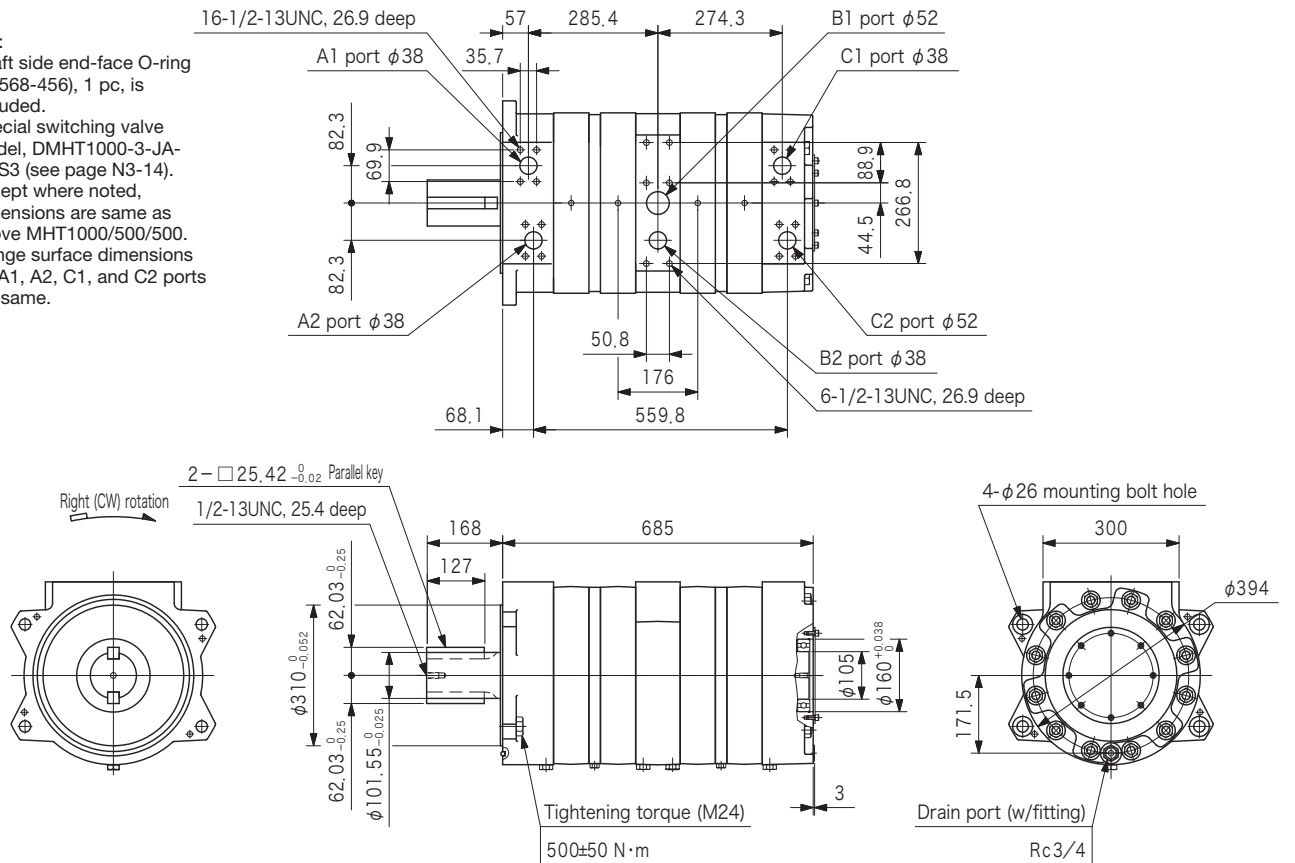

Dimensions

DMHT32-2-JA-10

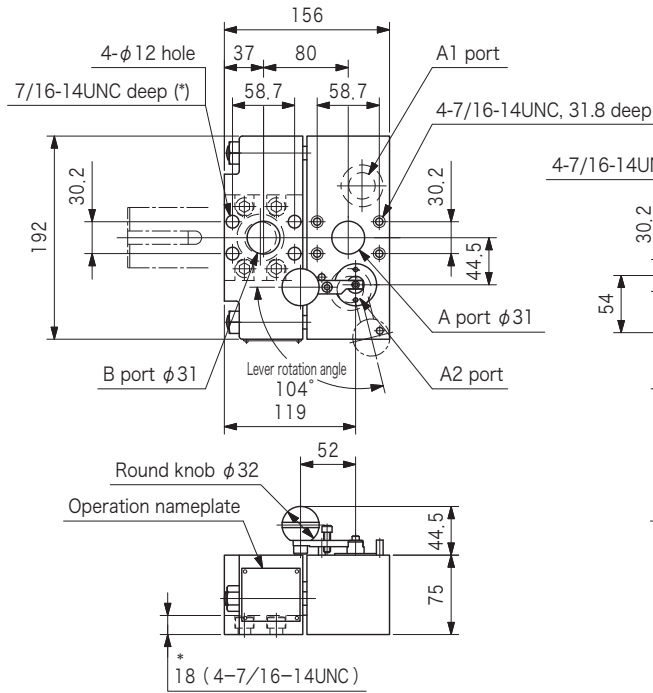

DMHT50-2-JA-10

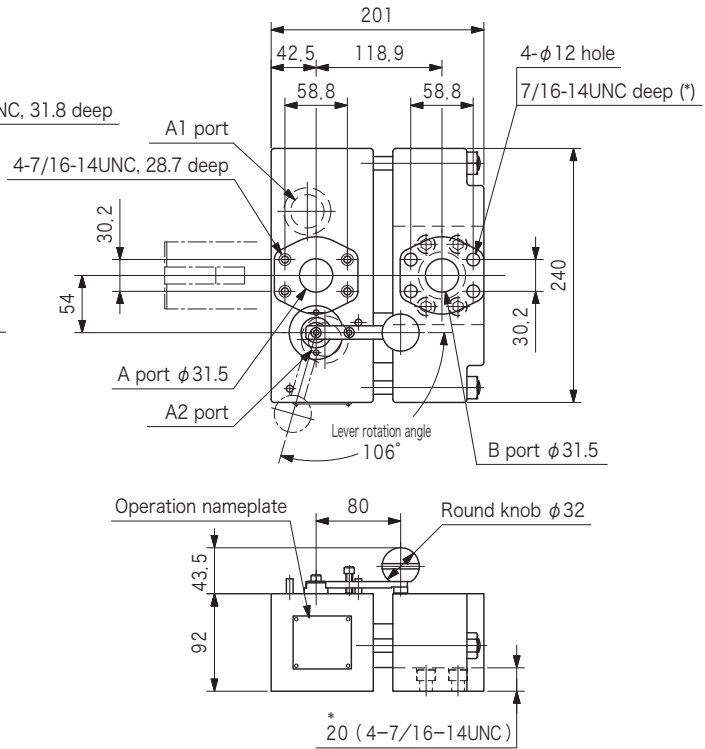

DMHT90-2-JA-10

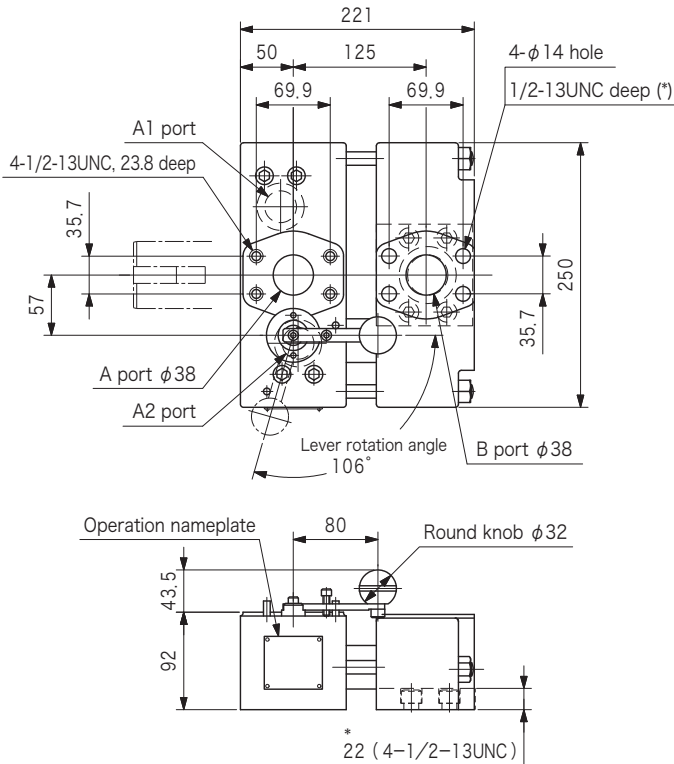

DMHT150-2-JA-10

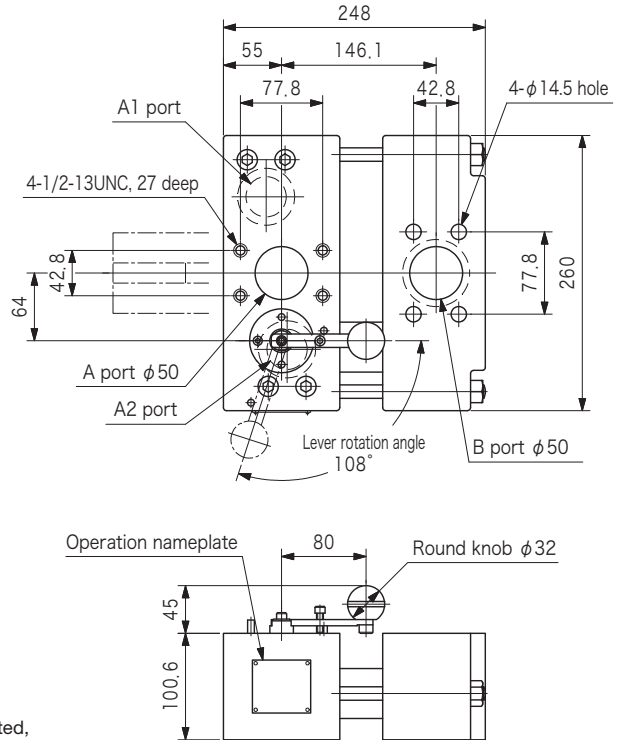

DMHT90-3-JA-10

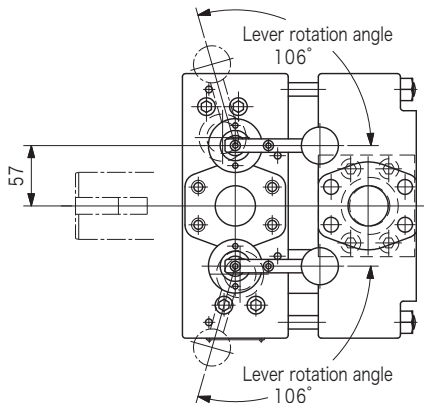

Note:
 • Except otherwise noted, dimensions are same as above DMHT90-2-JA-10.

Dimensions

DMHT250-2-10-JA-S1
 DMHT500-2-10-JA-S1
 DMHT750-2-10-JA-S1
 DMHT1000-2-10-JA-S1

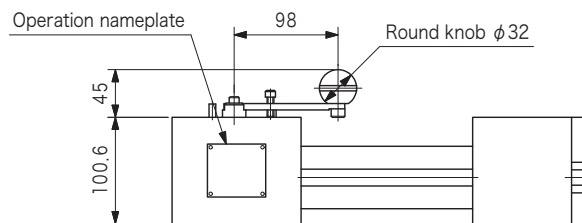
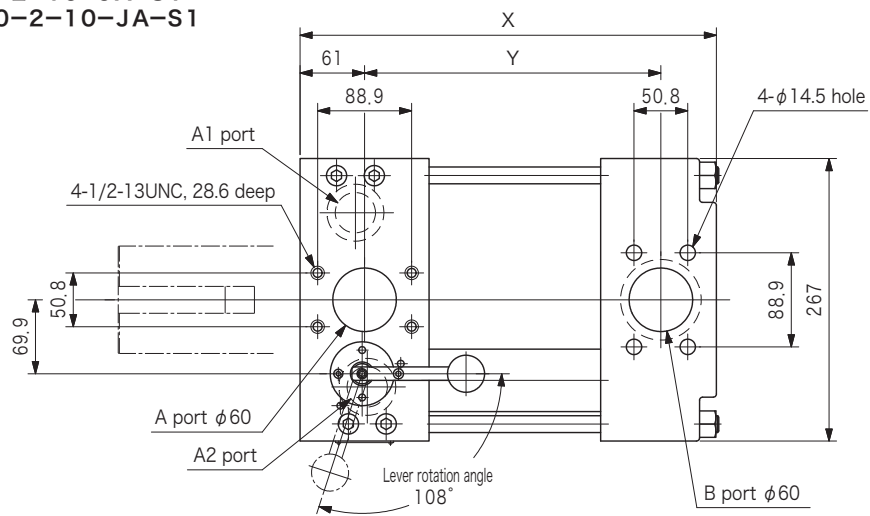

Dimensions table

Model Code	X	Y
DMHT250	291	177
DMHT500	394	280
DMHT750	497	383
DMHT1000	600	486

DMHT750-3-JA-10-S3
 DMHT1000-3-JA-10-S3

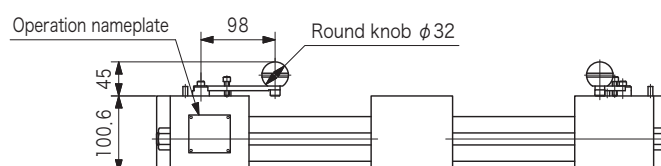
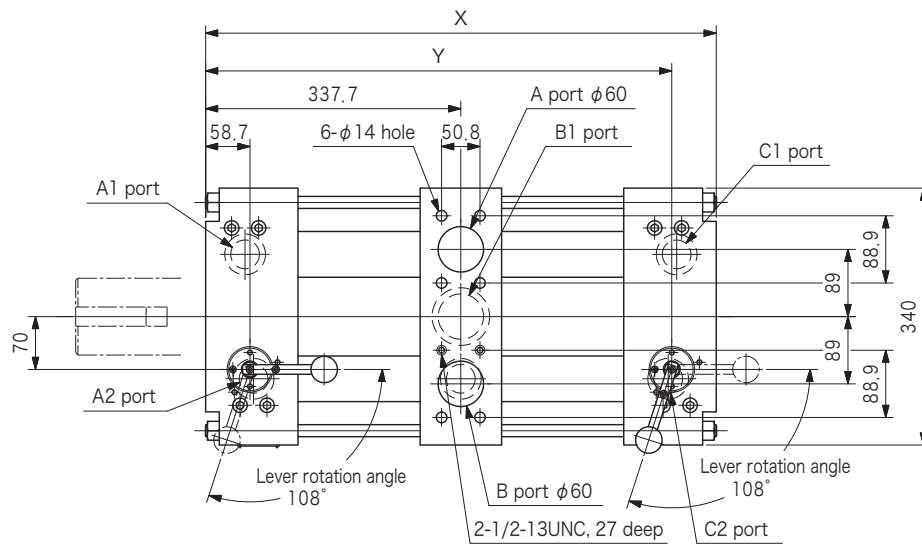

Dimensions table

Model Code	X	Y
DMHT750	572.3	513.6
DMHT1000	675.5	616.8

Construction

MHT24 to MHT32-S12
MHT50

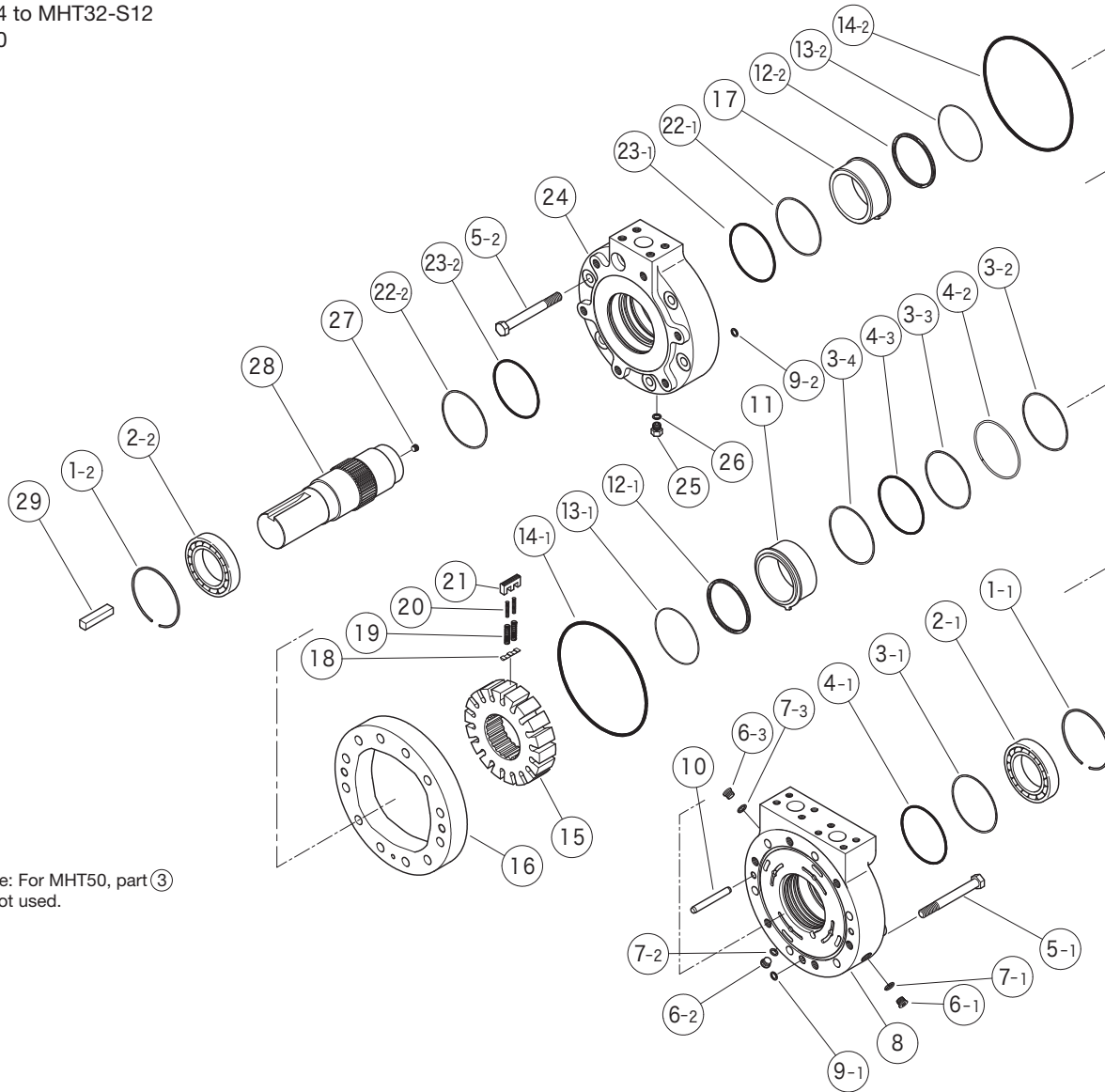

Note: For MHT50, part ③ is not used.

MHT24/12/12-S12
MHT32/16/16-S12 (Seal kit No.: 40098042)

No.	Name	Part No.	Standard	Qty
2	Bearing	40012193	JIS B 1521 6012ZZ	2
3	Backup ring	VA21304	—	4
4	O-ring	007904319	AS568-043 (NBR, Hs90)	3
7	O-ring	007990619	AS568-906 (NBR, Hs90)	3
9	O-ring	007901219	AS568-012 (NBR, Hs90)	2
12	X-ring	VP429290	—	2
14	O-ring	007926219	AS568-262 (NBR, Hs90)	2
22	Backup ring	VA15590	—	2
23	O-ring	007915319	AS568-153 (NBR, Hs90)	2
26	O-ring	007990419	AS568-904 (NBR, Hs90)	1

MHT50/25/25 (Seal Kit No.: 40098043)

No.	Name	Part No.	Standard	Qty
2	Bearing	40012194	JIS B 1521 6013ZZ	2
4	O-ring	007904419	AS568-044 (NBR, Hs90)	3
7	O-ring	007990819	AS568-908 (NBR, Hs90)	3
9	O-ring	007911219	AS568-112 (NBR, Hs90)	2
12	X-ring	VP427689	—	2
14	O-ring	007926819	AS568-268 (NBR, Hs90)	2
22	Backup ring	VA15596	—	2
23	O-ring	007923919	AS568-239 (NBR, Hs90)	2
26	O-ring	007990619	AS568-906 (NBR, Hs90)	1

N
3-15

Motors (Vane)

Construction

MHT70 to MHT1000-S123

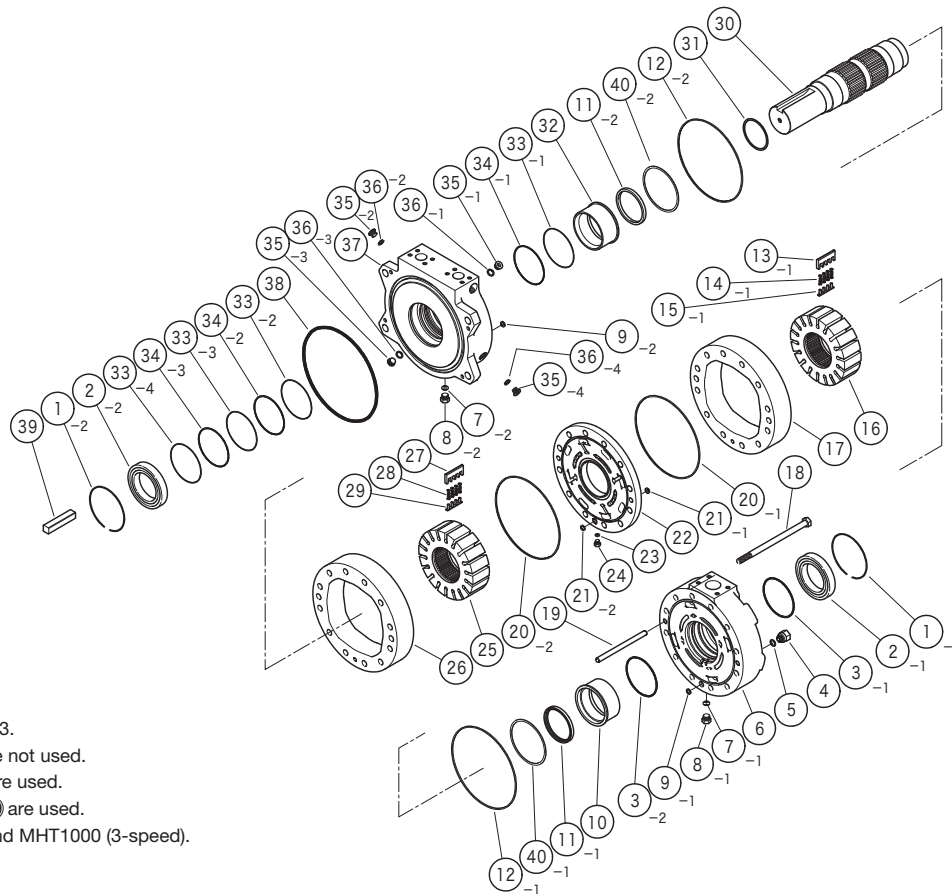

Note:

- Schematics show MHT380, MHT500-S123.
- For MHT70 to MHT250, parts 20 to 29 are not used.
- For MHT750, two sets of parts 20 to 29 are used.
- For MHT1000, three sets of parts 20 to 29 are used.
- See page N3-17 for MHT750 (4-speed) and MHT1000 (3-speed).

MHT70/35/35-S123

MHT70/45/25-S123

MHT90/45/45-S123 (Seal kit No.: 40098044)

No.	Name	Part No.	Standard	Qty
2	Bearing	40012195	JIS B 1521 6014ZZ	2
3	O-ring	007924119	AS568-241 (NBR, Hs90)	2
5	O-ring	007990619	AS568-906 (NBR, Hs90)	1
7	O-ring	007990619	AS568-906 (NBR, Hs90)	2
9	O-ring	007911219	AS568-112 (NBR, Hs90)	2
11	Shaft seal	40011705	—	2
12	O-ring	007927119	AS568-271 (NBR, Hs90)	2
33	Backup ring	VA15592	—	4
34	O-ring	007915519	AS568-155 (NBR, Hs90)	3
36	O-ring	007991019	AS568-910 (NBR, Hs90)	3
38	O-ring	007945019	AS568-450 (NBR, Hs90)	1

MHT150/75/75-S123 (Seal kit No.: 40088603)

No.	Name	Part No.	Standard	Qty
2	Bearing	40012196	JIS B 1521 6016ZZ	2
3	O-ring	007924619	AS568-246 (NBR, Hs90)	2
5	O-ring	007990619	AS568-906 (NBR, Hs90)	1
7	O-ring	007990619	AS568-906 (NBR, Hs90)	2
9	O-ring	007911219	AS568-112 (NBR, Hs90)	2
11	Shaft seal	VA31071	—	2
12	Seal	40012879	—	2
33	Backup ring	VA15594	—	4
34	O-ring	007915719	AS568-157 (NBR, Hs90)	3
36	O-ring	007991219	AS568-912 (NBR, Hs90)	3
38	O-ring	007945019	AS568-450 (NBR, Hs90)	1

MHT190/95/95-S123

MHT250/125/125-S123 (Seal kit No.: 40098040)

MHT750/375/375-S123 (Seal kit No.: 40098046)

MHT380/190/190-S123

MHT500/250/250-S123 (Seal kit No.: 40078757)

MHT1000/500/500-S123 (Seal kit No.: 40098048)

No.	Name	Part No.	Standard	Qty			
				MHT190 MHT250	MHT380 MHT500	MHT750	MHT1000
2	Bearing	40012197	JIS B 1521 6021ZZ	2	2	2	2
3	O-ring	007925419	AS568-254 (NBR, Hs90)	2	2	2	2
5	O-ring	007991019	AS568-910 (NBR, Hs90)	1	1	1	1
7	O-ring	007991019	AS568-910 (NBR, Hs90)	2	2	2	2
9	O-ring	007911419	AS568-114 (NBR, Hs90)	2	2	2	2
11	Shaft seal	VA30972	—	2	2	2	2
12	Seal	40012880	—	2	2	2	2
20	Seal	40012880	—	—	2	4	6
21	O-ring	007911419	AS568-114 (NBR, Hs90)	—	2	4	6
23	O-ring	007990619	AS568-906 (NBR, Hs90)	—	1	2	3
33	Backup ring	VA21130	—	4	4	4	4
34	O-ring	007916119	AS568-161 (NBR, Hs90)	3	3	3	3
36	O-ring	007991219	AS568-912 (NBR, Hs90)	4	4	4	4
38	O-ring	007945619	AS568-456 (NBR, Hs90)	1	1	1	1

MHT750/625/500/375-S123
MHT1000/750/500-S123

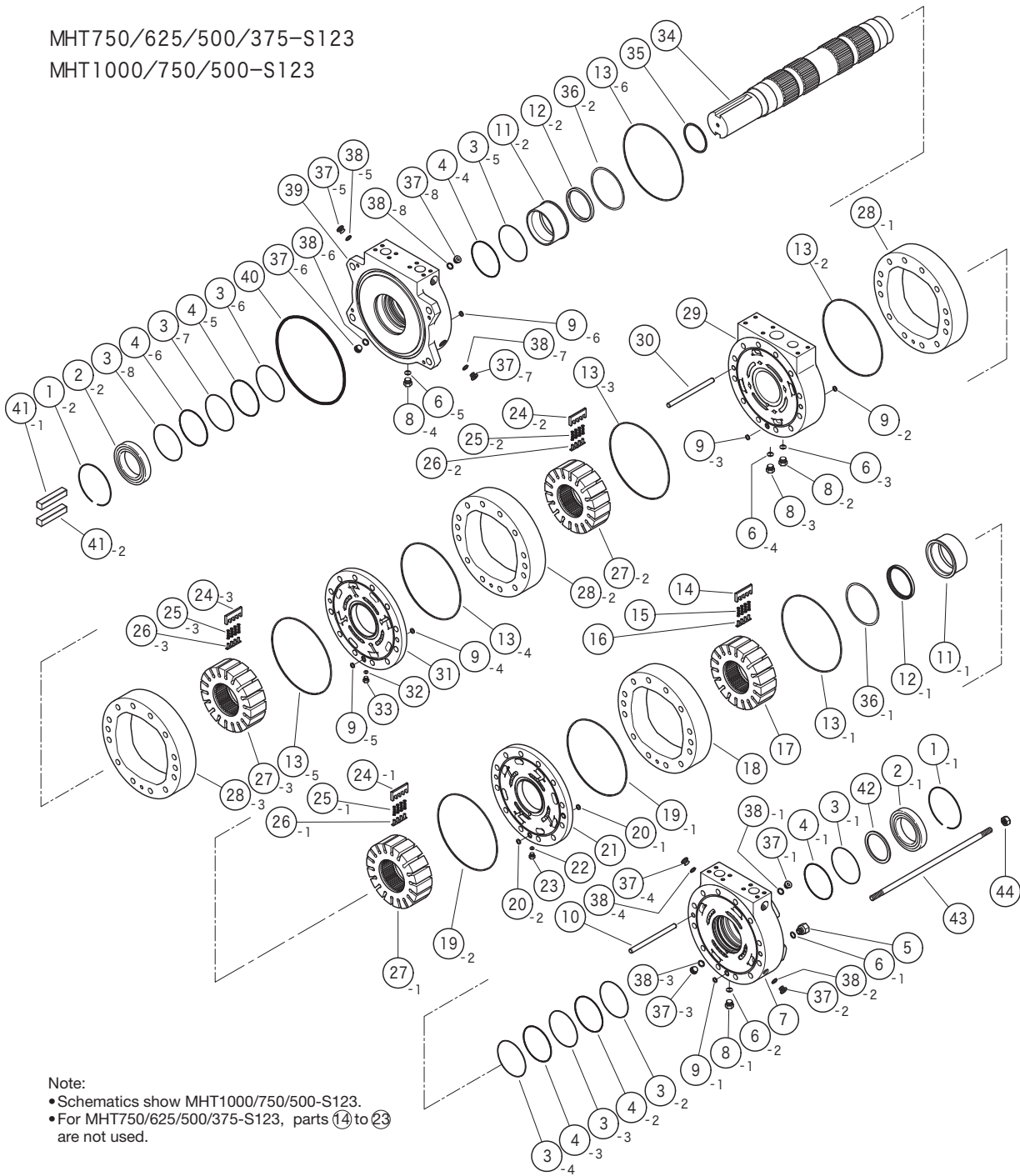

Note:
• Schematics show MHT1000/750/500-S123.
• For MHT750/625/500/375-S123, parts (14) to (23) are not used.

N
3-17

Motors (Vane)

MHT750/625/500/375-S123 (Seal kit No.: 40088545)
MHT1000/750/500-S123 (Seal kit No.: 40098055)

No.	Name	Part No.	Standard	Qty	
				MHT750/625/500/375	MHT1000/750/500
2	Bearing	40012197	JIS B 6021ZZ	2	2
3	Backup ring	VA21130	—	8	8
4	O-ring	007916119	AS568-161 (NBR, Hs90)	6	6
6	O-ring	007991019	AS568-910 (NBR, Hs90)	5	5
9	O-ring	007911419	AS568-141 (NBR, Hs90)	6	6
12	Shaft seal	VA30972	—	2	2
13	Seal	40012880	—	6	6
19	Seal	40012880	—	—	2
20	O-ring	007911419	AS568-141 (NBR, Hs90)	—	2
22	O-ring	007990619	AS568-906 (NBR, Hs90)	—	1
32	O-ring	007990619	AS568-906 (NBR, Hs90)	1	1
38	O-ring	007991219	AS568-912 (NBR, Hs90)	8	8
40	O-ring	007945619	AS568-456 (NBR, Hs90)	1	1