

# Pressure release valves TGMFS-5, 50 series

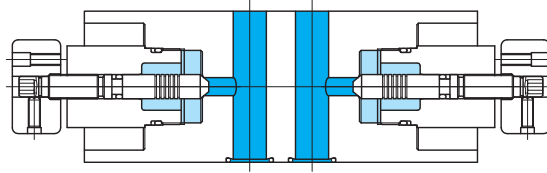

## Functional Symbol

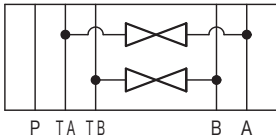

## Model Code

**(F3)-TGMFS-5-ATH-BTH-50**

1 2 3 4 5 6 7 8

**1** Hydraulic fluid

Omit: mineral oil based fluid, water-glycol based fluid  
F3: phosphate ester

**2** Pressure release valve

**3** Mounting dimensions

5: ISO 4401-05

**4** Control line

AT: A-T flow

**5** Adjuster

H: knob

**6** Control line

BT: B-T flow

**7** Adjuster

H: knob

**8** Design no.

## Specifications

- Max. Working Pressure: 31.5 MPa
- Max. Flow: 120 L/min (Ports P, A, B, T)  
40 L/min (A-T, B-T flow)

## Characteristics Curve (at 20 mm<sup>2</sup>/s, 50°C) (typical examples)

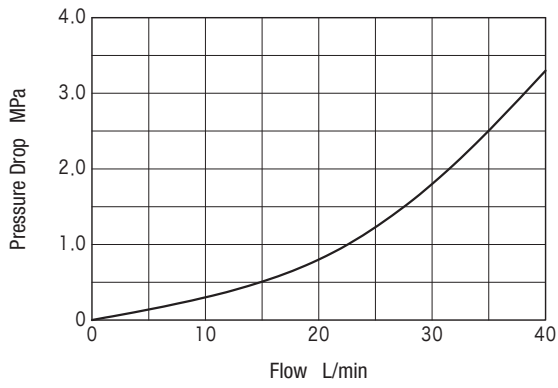

## Dimensions

Weight: 2.9 kg

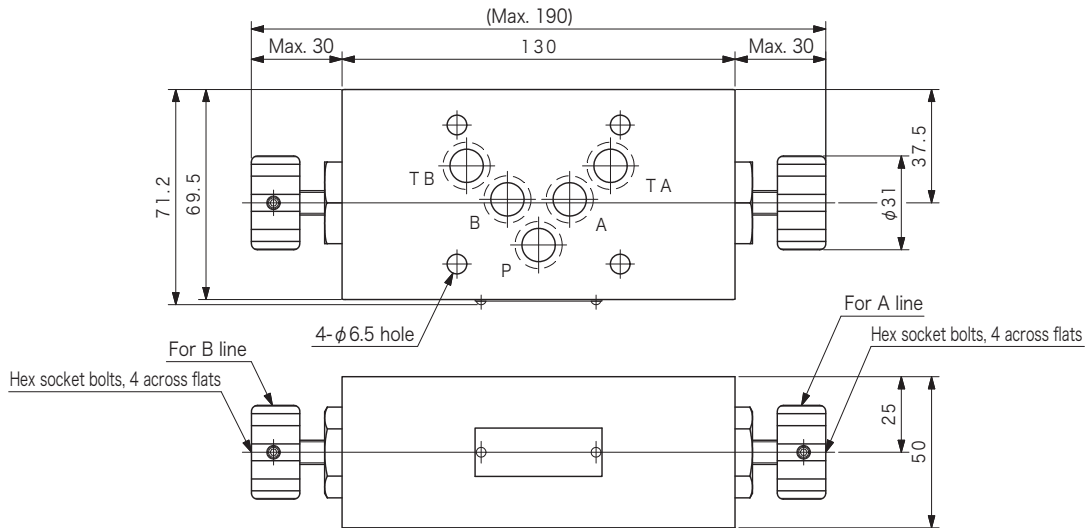

## Construction

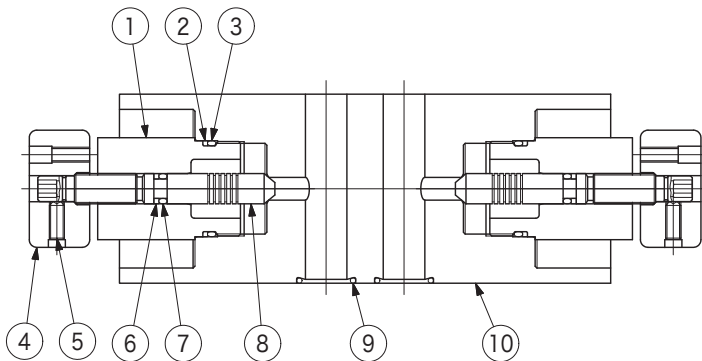

No.	Name	Part No.	Standard	Qty
2	Backup ring	40025055	—	2
3	O-ring	007902017	AS568-020 (NBR, Hs70)	2
6	Backup ring	40025095	—	2
7	O-ring	007900817	AS568-008 (NBR, Hs70)	2
9	O-ring	007901419	AS568-014 (NBR, Hs90)	5