

TGM-3, 50 series (ISO 4401-03)

Common Specifications

- Max. working pressure: 31.5 MPa
- Max. flow: 60 L/min
- Ambient temperature: -20°C~+80°C
- Hydraulic fluid
 - Working temperature: -20°C~+80°C (mineral oil)
+10°C~+54°C (water based)
 - Max. recommended temperature:
+65°C (to prevent fluid deterioration)
 - Recommended viscosity: 13~54 mm²/s
At startup (max.): 500 mm²/s
- Seals and fluids
Standard seals are nitrile rubber which are suitable for anti-wear hydraulic fluids, and water-glycol fluids.
- External piping connection port thread
Gauge port (G) of each stack valve is configured for G1/8 O-ring seal. Special couplings (G1/8-Rc1/4 change coupling, see Fig. 2) for gauge port are available.
When port of adaptor plate (tapping plate) is parallel thread, use bonded seal (seal washer, P/N: 48781938) for piping.
Coupling used should have seating surface dimension greater than 14 (round or hex) and diameter less than max. 22.
- Mounting dimensions (see Fig. 1)
Care should be paid when mounting, per ISO 4401-03 and figure, as positioning pin is not used.

- Mounting bolts
 - Use M5-6g (strength class 12.9) mounting bolts - JIS B 1176 (hex socket bolts).
 - Mounting bolt length should be greater than uppermost valve bolt tightening length + total height of stacked valves +7.5.
 - Tightening torque: 7~8 N·m
 - Mounting bolts must be ordered separately.
- Valves can be mounted at any attitude.
- Options
 - Adjuster
Hex socket adjustment screw (W) is standard. Handle knob adjuster (H) also available.
- Characteristics curve
Characteristics curve are based on fluid viscosity 20 mm²/s (fluid temperature 50°C), specific gravity 0.87. (see "Notes".)
- Other
 - Width across flats dimensions of parts allow use of metric and inch tools.
 - O-ring groove on mounting surface employ proprietary trapezoidal groove to prevent O-ring intrusion by flow forces.

Notes:

1. For pressure drops (ΔP_1) of viscosities other than 20 mm²/s, calculate using multiplier coefficients shown in below table.
2. The formula to calculate pressure drops (ΔP_1) for specific gravities other than 0.87 is as follows.

$$\Delta P_1 = \Delta P \times G_1 / G \quad G \dots 0.87$$

$\Delta P \dots$ Values according to characteristics curve
 $G_1 \dots$ Desired specific gravity value

Viscosity mm ² /s	10	20	30	40	50	60	70	80	90	100	110	120	130	140	150
Coefficient	0.85	1.00	1.09	1.17	1.24	1.29	1.34	1.38	1.42	1.46	1.49	1.52	1.56	1.59	1.62

Fig. 1 Mounting dimensions

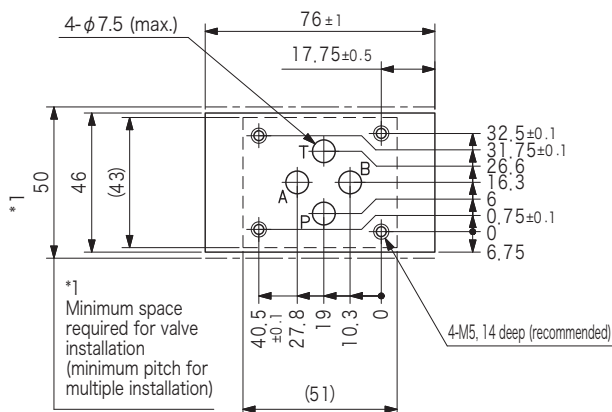

• Solid lines are seating dimensions of stack valve bodies, dotted lines are min. required seating surface dimensions.

*1 Set the mounting pitch to 52 mm or more when P ports are to be installed adjoining each other (with the nameplates facing each other).

- Normal mounting-related dimensional tolerance ± 0.2 (unless otherwise indicated)
- Mounting surface machining accuracy

Surface Roughness	1.6 μ m Ra	1.6
Flatness	Less than 0.01 (\square per 100 mm)	0.01 / \square 100

Fig. 2 Special coupling for gauge port (G)

Part No.: 40025980

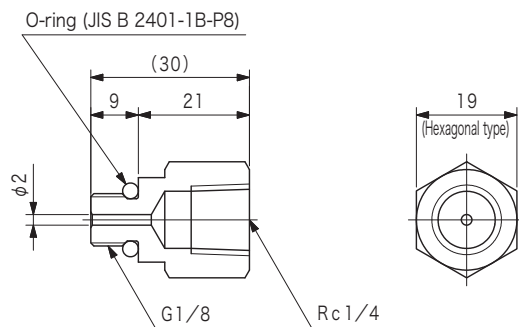

- Coupling which changes G1/8 to Rc1/4.
- Max. working pressure.....21 MPa
- O-rings are not included. (Part No.: 008000619)

TGM-3, 50 series (ISO 4401-03)

Mounting Bolts

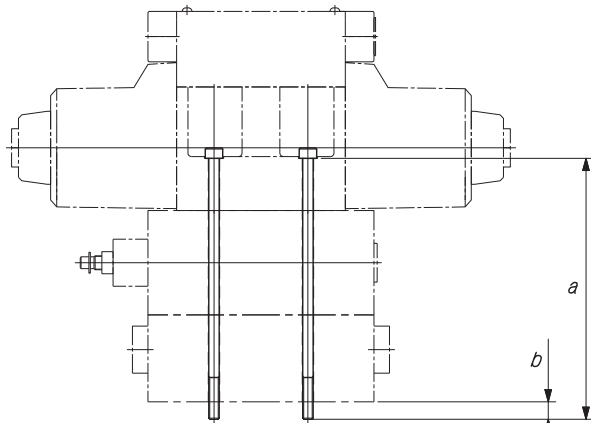

b thread engagement: length should be longer than 9.

• O-Ring Dimensions

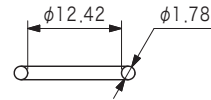

O-ring
No. AS568-014

Pressure Switches DGMPS	Solenoid Valves DG4V	Stack Valves Pressure, Flow, Direction	Tapping Plates	Blanking Plate	Crossover Plates	Bolt Thread Engagement <i>b</i> mm	Bolt Length <i>a</i> mm	M5
								Bolt Part No.
Mounted Height mm								
60	38	40	20	10	10	10	20	001950201
	1			1		12	50	001950501
		1			1	10	60	001950601
		1	1	1		10	80	001950801
	1	1				12	90	001950901
		2			1	10	100	VP417414
	1	1	1			12	110	VP417415
1	1	2	1		1	10	120	VP417416
		2				12	130	VP417417
		3		1		10	140	VP417418
	1	2	1			12	150	VP417419
1	1	1				10	160	VP417420
		3	1		1	12	170	VP417421
	1	3						

Subplate

Subplate Model		Connection Port Dia. Rc
Side Piping	DGMS-3-1E-10-T-JA-J	3/8
Bottom Piping	DGVM-3-10-T-JA-J	

- Subplate must be ordered separately.
- See page R6-6 for dimensions.
- See page R6-6 for plural mount subplates.
- Max. working pressure is 21 MPa. For higher pressures, install on a manifold block, etc.

Precautions for configuring systems with stack valves

Modular Circuit Stack Restrictions

Depending on the valve function, there may be restrictions on the stacking order of some of the valves which are similar to restrictions when using valves other than stack valves.

The illustrations below show some recommended configurations for smooth flow control and leakage measures.

Name	Incorrect Stacking Example	Correct Stacking Example	Description
<p>Solenoid Valves</p> <p>One-Way Restrictors (Meter-out)</p> <p>Pilot Operated Check Valves</p>	<p>Figure A₁</p>	<p>Figure A₂</p>	<ul style="list-style-type: none"> ● One-way restrictor (meter out) and pilot operated check valve <p>In Fig. A₁, when the cylinder rod is retracted, meter out control by the one-way restrictor in B line causes back pressure in the area indicated by the arrow.</p> <p>Because of this back pressure, although the pilot operated check valve in B line will act to close the valve, when the check valve is closed, back pressure in the area indicated by the arrow will cause the check valve to reopen.</p> <p>This may cause unstable operation and result in “knocking” of the cylinder.</p> <p>Fig. A₂ is example of the recommended configuration which prevents this problem.</p>
<p>Solenoid Valves</p> <p>One-Way Restrictors (Meter-out)</p> <p>Reducing valve (B-line pilot)</p>	<p>Figure B₁</p>	<p>Figure B₂</p>	<ul style="list-style-type: none"> ● One-way restrictor (meter out) and reducing valve (A, B line pilot) <p>In Fig. B₁, when the cylinder rod is retracted, meter out control by the one-way restrictor in B line causes back pressure in the area indicated by the arrow.</p> <p>Pilot pressure to the reducing valve taken from B line may cause the spool to close and block flow.</p> <p>Fig. B₂ is example of the recommended configuration which prevents this problem.</p>
<p>Solenoid Valves</p> <p>Pilot Operated Check Valves</p> <p>Reducing valve (B-line pilot)</p>	<p>Figure C₁</p>	<p>Figure C₂</p>	<ul style="list-style-type: none"> ● Pilot operated check valve and reducing valve (A, B line pilot) <p>In Fig. C₁, when cylinder is stopped in mid-position, the cylinder may not be able to maintain its position due to internal leakage from the pilot line of the B line reducing valve.</p> <p>Fig. C₂ is example of the recommended configuration which prevents this problem.</p>